

(Conducted on 29.12.2019)

General Engineering Paper II

Civil and Structural

1. (a) For a town with population of 2 lakhs a water supply scheme is to be designed. The maximum daily demand may be assumed as 200 litre/capita/day. The storage reservoir is situated 5 km away from the town. Assuming loss of head from source to town as 10 m and coefficient of friction for the pipe material as 0.012, recommend the size of supply main. 30% of the daily demand has to be pumped in 8 hours for the proposed scheme. (15)
- (b) A certain clay layer has a thickness of 5 m. After 1 year, when the clay was 50% Consolidated, 8 cm of settlement had occurred. For a similar clay and loading conditions, how much settlement would occur at the end of 1 year and 4 years respectively, if the thickness of new layer is 25 m ? (15)
- (c) What is efficiency and explain different kinds of irrigation efficiencies ? (15)
- (d) The speed of overtaking and overtaken vehicles are 70 and 40 kmph, respectively on a two way traffic road. The average acceleration during overtaking may be assumed as 0.99 m/s^2 .
- (i) Calculate safe overtaking sight distance. (15)
- (ii) What is the minimum length of overtaking zone and draw a neat sketch of the Overtaking zone and show the position of sign post. (15)

2. (a) What are the requirements of an ideal permanent way? Draw a dimensional cross section of a BG track in embankment on a straight track and mark the details. (15)

(b) The following are bearings taken on a closed compass traverse : (15)

LINE	F.B.	B.B.
AB	$80^{\circ}10'$	$259^{\circ}0'$
BC	$120^{\circ}20'$	$301^{\circ}50'$
CD	$170^{\circ}50'$	$350^{\circ}50'$
DE	$430^{\circ}10'$	$49^{\circ}30'$
EA	$310^{\circ}20'$	$130^{\circ}15'$

Compute the interior angles and correct them for observational errors.

Assuming the Observed bearing of the line CD to be correct, adjust the bearing of remaining sides. (10)

(c) Mention the factors governing selection of dam site. (15)

(d) Design a regime channel for a discharge of $35 \text{ m}^3/\text{s}$ with silt factor of 0.9 by Lacey's theory taking side slopes as 1H : 2V. (15)

3. (a) Describe Direct shear test with the help of neat diagram and mention its advantages (20)
- (b) Design a simply supported roof slab for a room 8 m × 3.5 m clear in size if the Superimposed load is 5 kN/m². Use M15 mix and Fe 415 grade steel. Use limit state method of design. (25)

100 As/bd	0.15	0.25	0.50	0.75	1.0
τ_e (N/mm ²)	0.19	0.36	0.49	0.57	0.64

- (c) Design a rectangular beam to resist a bending moment of working load equal to 45 kNm using M15 and mild steel? (15)

4. (a) What is workability of concrete? Explain slump test and compacting factor test. Discuss the factors affecting workability. (20)
- (b) A trapezoidal channel has a bottom width of 3 m and side slopes of 1.5 horizontal : 1 vertical. The longitudinal slope of channel is 0.0004. (a) Calculate the average Shear stress on the channel boundary when the flow takes place at a uniform depth of 1.25 m, if the Manning's roughness coefficient of the channel boundary is 0.012? (15)
- (c) A pelton wheel has a mean bucket speed of 10 m/s with a jet of water flowing at the rate of 700 litres/s under a head of 30 m. The buckets deflect the jet through an angle of 160° . Calculate the power given by water to the runner and the hydraulic efficiency of the turbine. Assume coefficient to velocity as 0.98. (15)
- (d) What are the characteristics of good quality of timber? (10)

5. (a) For the retaining wall shown in the figure, determine the lateral earth force at rest per unit length of wall. Also determine the location of resultant force and also draw the pressure distribution diagram.

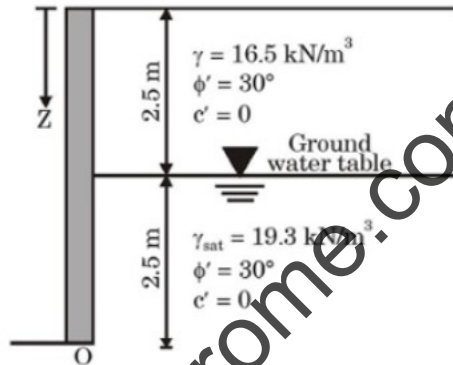

- (b) 500g of dry soil was subjected to sieve analysis. The weight of soil retained on the Sieve is as follows :

IS sieve size	Wt. of soil, g	IS sieve size	Wt. of soil, g
4.75 mm	10	425 μ	85
2.00 mm	165	212 μ	40
1.00 mm	100	150 μ	30
		75 μ	50

Plot the grain size distribution curve and determine the following :

- Percentages of gravel, coarse sand, medium sand, fine sand and slit-clay fraction in the soil.
- Effective size
- Uniformity coefficient
- Coefficient of curvature

- (iv) Coefficient of curvature (20)
- (c) A 30 cm diameter well penetrates 25 m below the static water table. After 24 hours of pumping @5400 litres/minute, the water level in a test well at 90 m is lowered by 0.53 m and in a well 30 m away the drawdown is 1.1 m.

- (i) What is transmissibility of the aquifer?
- (ii) Also determine the drawdown in the main well.

6. (a) A welded bracket connection is shown in figure. It supports a factored load of 150 kN at a distance of 120 mm from the face of column. Design the fillet weld on two sides. Grade of steel = Fe 410 $f_y = 250 \text{ MPa}$ (25)

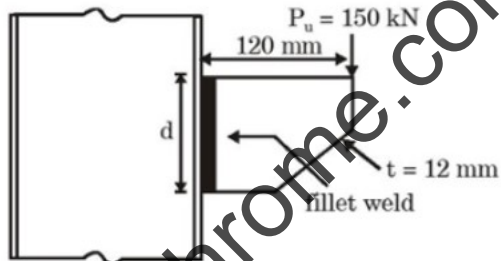

- (b) Draw the Shear Force and Bending Moment diagram for the beam shown (20)

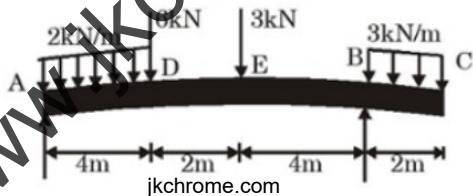

- (c) Define the following terms:

Depreciation, Sinking fund, Salvage value, methods of valuation.

(15)

JK Chrome

JK Chrome | Employment Portal



Rated No.1 Job Application of India

Sarkari Naukri
Private Jobs
Employment News
Study Material
Notifications

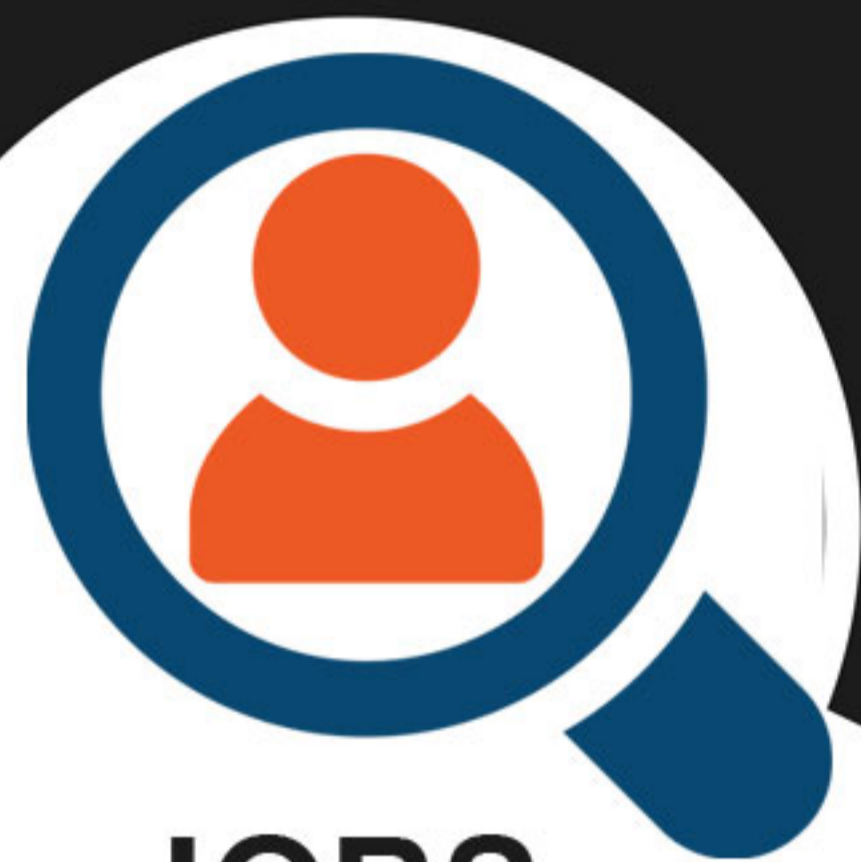

JOBS



NOTIFICATIONS



G.K



STUDY MATERIAL

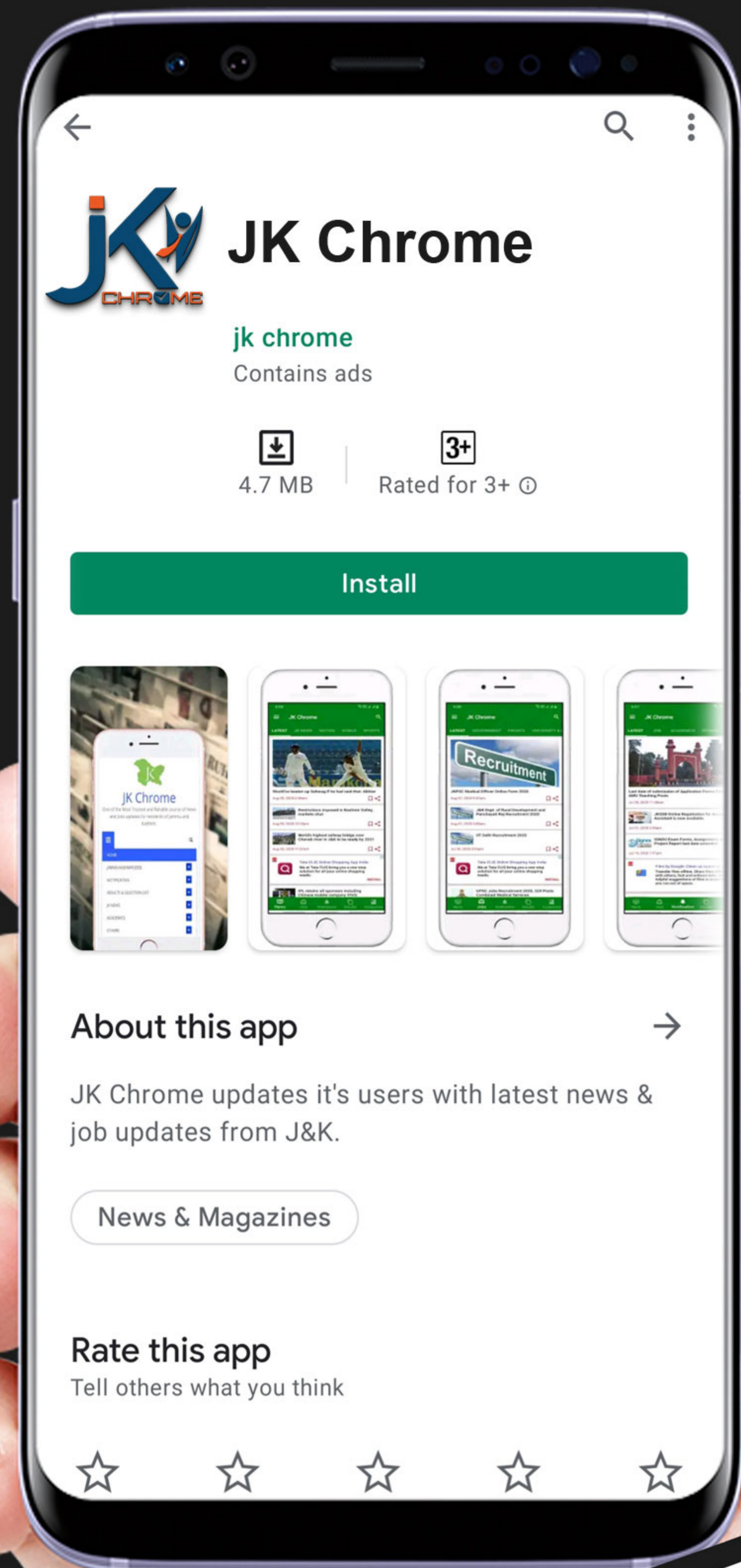

JK Chrome

jk chrome
Contains ads



www.jkchrome.com | Email : contact@jkchrome.com

Tabel 1 : Permissible Stresses in Concrete

(Clauses B-1.3, B-2.1, B-2.1.2, B-2.3 and B-4.2)

jkchrome.com

jkchrome.com

All values in N/mm²

Grade of Concrete	Permissible Stress in Compression		Permissible Stress in Bond (Average) for Plain Bars in Tension
	Bending	Direct	
(1)	(2)	(3)	(4)
	σ_{cbc}	σ_{cc}	τ_{bd}
M 10	3.0	2.5	—
M 15	5.0	4.0	0.6
M 20	7.0	6.0	0.8
M 25	8.5	7.0	0.9
M 30	10.0	8.0	1.0
M 35	11.5	9.0	1.1
M 40	13.0	10.0	1.2
M 45	14.5	11.0	1.3
M 50	16.0	12.0	1.4

jkchrome.com

jkchrome.com

jkchrome.com

Notes :

1. The values of permissible shear stress in concrete are given in Table 23.
2. The bond stress given in column 4 shall be increased by 25 percent for bars in compression.

Table 23 : Permissible Shear Stress in Concrete

(Clauses B-2.1, B-2.3, B-4.2, B-5.2.1 B-5.2.2, B-5.3, B-5.4, B-5.5.1, B-5.5.3, B-6.3.2, B-6.3.3 and B-6.4.3 and Table 21)

100 A _s bd	Permissible Shear Stress in Concrete, τ_c N/mm ² Grade of Concrete					
	M 15	M 20	M 25	M 30	M 35	M 40 and above
(1)	(2)	(3)	(4)	(5)	(6)	(7)
≤0.15	0.18	0.18	0.19	0.20	0.20	0.20
0.25	0.22	0.22	0.23	0.23	0.23	0.23
0.50	0.29	0.30	0.31	0.31	0.31	0.32
0.75	0.34	0.35	0.36	0.37	0.37	0.38
1.00	0.37	0.39	0.40	0.41	0.42	0.42
1.25	0.40	0.42	0.44	0.45	0.45	0.46
1.50	0.42	0.45	0.46	0.48	0.49	0.49
1.75	0.44	0.47	0.49	0.50	0.52	0.52
2.00	0.44	0.49	0.51	0.53	0.54	0.55
2.25	0.44	0.51	0.53	0.55	0.56	0.57
2.50	0.44	0.51	0.55	0.57	0.58	0.60
2.75	0.44	0.51	0.56	0.58	0.60	0.62
3.00 and above	0.44	0.51	0.57	0.60	0.62	0.63

Note : A_s is the area of longitudinal tension reinforcement which continues at least one effective depth beyond the section being considered except at support where the full area of tension reinforcement may be used provided the detailing conforms to 26.2.2 and 26.2.3.

Tabel 24 : Maximum Shear Stress, $\tau_{c \max}$ N/mm²

(Clauses B-5.2.3, B-5.2.3.1, B-5.5.1 and B-6.3.1)

Concrete Grade	M 15	M 20	M 25	M 30	M 35	M 40 and above
$\tau_{c \max}$ N/mm ²	1.0	1.8	2.0	2.2	2.5	2.5

Question Paper 2017

Civil Engineering (Paper II)

1. (a) Determine the dissolved oxygen at the end of 2 days for the following data: (15)

Characteristics	Stream water	Waste water
Flow (m ³ /sec)	22	3
DO (mg/litre)	10	0
BOD (mg/litre)	3	190

Assume :

Deoxygenation constant $K = 0.11$ per day

Reoxygenation constant $R = 0.33$ per day

- (b) A clay stratum has 2.5 m thickness and has initial overburden pressure of 45 kN/m². The clay is over consolidated with a preconsolidation pressure of 65 kN/m². Find the final settlement due to increment of pressure of 55 kN/m² at the middle of clay layer. Use the following data:

Initial void ratio = 1.2

Compression index = 0.27

Swelling index = 0.06 (15)

- (c) Discuss the factors affecting duty of water (15)
- (d) Calculate the safe overtaking sight distance. For a design speed of 100 km/hr. Assume maximum overtaking acceleration as 1.92 km/hr/sec. (15)

2. (a) What are the requirements of a good ballast in railway engineering? Explain how the minimum depth of ballast cushion is estimated. (15)

- (b) Determine the correct bearings of the lines of a closed traverse PQRSTP. The readings are as follows:

Line	Fore bearing	Back bearing
PQ	195°30'	17°0'
QR	73°30'	250°30'
RS	36°15'	214°30'
ST	266°45'	84°45'
TP	234°15'	57°0'

Identify the stations affected by local attraction. (20)

- (c) What are the factors affecting selection of contour interval? (10)

- (d) A trapezoidal dam with a vertical water face is 2.5 m wide at the top and 14 m wide at the base. The height of the dam is 27 m. Find the maximum depth of water so that the dam section is free from tension. Assume unit weight of dam material as 21 kN/m³ and that of water as 9.81 kN/m³. (15)

3. (a) Describe plate load test as per IS 1888. Discuss the limitations. What are the effects of size of plate on bearing capacity and settlement? (20)

- (b) A classroom is of the size 8.5 m × 3.6 m. Design a simply supported roof slab for this room. The superimposed load is 5 kN/m. Use M 20 grade concrete and HYSD Fe 415 steel. Use limit state method for the design. (25)

$100A_s / b_d$	0.15	0.25	0.50	0.75	1.0
$\tau_c N / \text{mm}^2$	0.19	0.36	0.49	0.57	0.64

- (c) Explain the steps for the design of column with helical reinforcement in limit state method. (15)

4. (a) What are the characteristics of a good quality timber? (10)

- (b) Derive the condition for the trapezoidal channel of best section. Prove that the hydraulic mean depth for such a channel is one-half the depth of flow. (15)

- (c) The discharge of a Pelton wheel turbine is 5 m³/sec at a head of 300 m at the nozzle. There are two runners and each runner has two jets. The length of the pipeline is 1900 m. The efficiency of the transmission for the pipe is 90%. Assume friction factor f as 0.008. Determine jet diameter, pipe diameter and output of the turbine. The overall efficiency of turbine is 85%. (15)

- (d) What is workability of concrete? Explain slump test and compacting factor test. Discuss the factors affecting workability. (20)

2 Question Paper 2017

5. (a) A 6 m high vertical wall supports a saturated cohesive soil with horizontal surface. The top 3.5 m of the backfill has bulk density 18 kN/m^3 and apparent cohesion of 16 kN/m^2 . The bulk density and apparent cohesion of the bottom 2.5 m is 19.5 kN/m^3 and 18 kN/m^2 respectively. What will be total active earth pressure on the wall? Draw the pressure distribution diagram. Assume that tension cracks will develop. Locate the point of application of the resultant pressure. (20)
- (b) A direct shear test was conducted on a silty sand. At failure the normal and shear stresses were found to be 66 kPa and 40 kPa respectively. Draw Mohr's circle and determine:
- Angle of shearing resistance
 - Principal stresses at failure
 - Locate the pole and find orientation of failure plane. (20)
- (c) The pump-out test was performed to determine the field permeability of an unconfined aquifer and the following observations were made:
- RL of original water table before pumping = 250.5 m
- RL of water in the well at constant pumping = 245.6 m
- RL of the rock of impervious layer = 230.0 m
- The distance of observation well from tubewell = 48 m (20)

Determine

- Coefficient of permeability of the aquifer (k)
- Error in k if observations are not taken in the observation well and radius of influence is assumed to be 298 m
- Actual radius of influence based on the observations of observation well
- Radius of influence using sichart equation

The diameter of the well is 20 cm and discharge is $250 \text{ m}^3/\text{hr}$.

6. (a) In a roof truss, the member consists of 2 ISA $100 \times 75 \times 8 \text{ mm}$. The angles are connected to either side of a 10 mm gusset plate and member is subjected to a working pull of 280 kN . Design the welded connection assuming they are made in the workshop. The centre of gravity of the section from the top may be considered 31 mm . (20)
- (b) Draw the shear force and bending moment diagram for the beam as shown below:

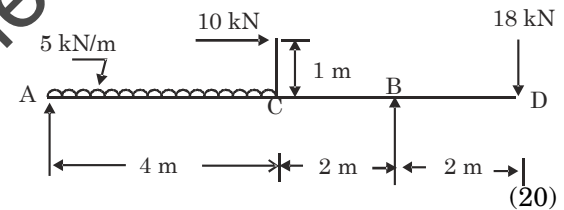

- (c) Define the following terms:
Scarp value, Salvage value, Sinking fund and Depreciation (20)

Question Paper 2016

Civil Engineering (Paper II)

1. (a) A town on the bank of river Ganga discharges 18000 m³/day of treated wastewater into the river. The treated wastewater has a BOD₅ of 20 mg/L, and a BOD decay constant of 0.12 day⁻¹ at 20°C. The river has a flow rate of 0.43 m³/sec and an ultimate BOD of 5.0 mg/L. The DO of the river is 6.0 mg/L and the DO of the wastewater is 0.4 mg/L. Compute the DO and initial ultimate BOD in the river, immediately after mixing. (15)
- (b) A sample of normally consolidated clay was subjected to a consolidated undrained triaxial compression test that was carried out until the specimen failed at a deviator stress of 50 kN/m². The pore water pressure at failure was recorded to be 20 kN/m² and confining pressure of 50 kN/m² was used in the test. Determine the consolidated undrained friction angle. (15)
- (c) Using Lacey's theory, design an irrigation channel carrying 30 m³/sec. Take silt factor as 1.0. (15)
- (d) Discuss the various causes of disintegration and the major faults occurring in WBM and surface treated (asphalt roads) in India. (15)
2. (a) Differentiate between the following with reference to bituminous construction: (15)
- (i) Prime coat and Tack coat
- (ii) Bituminous concrete and Bituminous macadam.
- (b) A road is to be constructed with a uniform rising gradient of 1 in 100. Determine the staff readings required for setting the tops of the two pegs on the given gradient at 30 meters interval from the last position of the instrument. The RL of the first peg is 384.500 m. A fly levelling was carried out from a BM of RL 387.000 m. The following observations (in m) were recorded: (15)

Backsight :	1.625	2.345	2.045	2.955
Foresight :	1.315	3.560	2.355	

- (c) What are the errors induced in theodolite survey? (15)
- (d) A solid shaft transmits 250 kW at 100 r.p.m. If the shear stress is not to exceed 75 N/mm², what should be the diameter of the shaft? If this shaft is to be replaced by a hollow shaft whose internal diameter shall be 0.6 times the outer diameter, determine the size and percentage saving in weight maximum stresses being the same. (15)
3. (a) Design a circular column with helical reinforcement subjected to a working load of 1500 kN. Diameter of the column is 450 mm. The column has unsupported length of 3.5 m and is effectively held in position at both ends but not restrained against rotation. Use limit state design method. Use M-25 concrete and HYSD Fe-415 steel. (25)
- (b) Design a constant thickness footing for a reinforced concrete column of 300 mm × 300 mm. The column is carrying an axial working load of 600 kN. The bearing capacity of soil is 200 kN/m². Use M-25 concrete and HYSD Fe-415 bars. Use limit state design method. (15)
- | | | | | | |
|-------------------------------|------|------|------|------|------|
| 100 (A_{st}/bd) | 0.15 | 0.25 | 0.50 | 0.75 | 1.0 |
| τ_c (N/mm ²) | 0.19 | 0.36 | 0.49 | 0.57 | 0.64 |
- (c) State and discuss different factors influencing compaction of soil in the field. (20)
4. (a) Classify the solid wastes, giving suitable example for each of them. Also explain the different methods of disposal of solid wastes. (15)
- (b) Estimate for 1 : 20 model of a spillway (i) prototype velocity corresponding to a model velocity of 2 m/sec, (ii) prototype discharge

2 Question Paper 2016

per unit width corresponding to a model discharge per unit width of $0.3 \text{ m}^3/\text{sec}/\text{m}$, (iii) pressure head in the prototype corresponding to a model head of 5 cm of mercury at a point, and (iv) the energy dissipated per second in the model corresponding to a prototype value of 1.5 kW. (15)

- (c) A centrifugal pump having an impeller of 35 cm outside diameter rotates at 1050 r.p.m. The vanes are radial at exit and are 7.0 cm wide. The velocity of radial flow through the impeller is 3 m/sec. The velocity in the suction and delivery pipes are 2.5 m/sec and 1.5 m/sec respectively. Neglecting frictional losses, determine the height through which the pump lifts and the horse-power of the pump. (15)
- (d) Name the four important constituents of cement and also state the role of each in achieving its properties. (15)

5. (a) A retaining wall with a smooth vertical back is 9 m high and retains a two-layer sand backfill with the following properties:

0 – 3 m depth : $c' = 0.0$, $\phi = 30^\circ$, $\gamma = 18 \text{ kN/m}^3$
 3 – 9 m depth : $c' = 0.0$, $\phi = 35^\circ$, $\gamma = 20 \text{ kN/m}^3$.

Show the active earth pressure distribution and determine the total active thrust on the wall. Assume that the water table is well below the base of the wall. (20)

- (b) A layer of sand 6.0 m thick lies above a layer of clay soil. The water table is at a depth of 2.0 m below the ground surface. The void ratio of the sand layer is 0.6 and the degree of saturation of the sand layer above the water table is 40%. The void ratio of the clay layer is 0.7. Determine the total stress, neutral stress and effective stress at a point 10 m below the ground surface. Assume specific gravity of the sand and clay soil respectively as 2.65 and 2.7. (20)
- (c) What is grit? Why should grit be removed from wastewater? What is the basic principle behind the design of grit chambers? What is the reason to have constant velocity of flow in a grit chamber (conventional horizontal flow) and how is it achieved? (20)

6. (a) Design riveted splices for a tie of a steel bridge, 20 cm wide, 20 mm thick, carrying an axial tensile force of 50,000 kg. Use 12 mm thick cover plates and 22 mm diameter rivets.

Permissible stresses :

- Tension in plates = 1500 kg/cm^2
- Shear in rivets = 1000 kg/cm^2
- Bearing in rivets = 3000 kg/cm^2

Give a neat sketch of the arrangement. (25)

(b) Draw BMD and SFD for the beam shown below: (25)

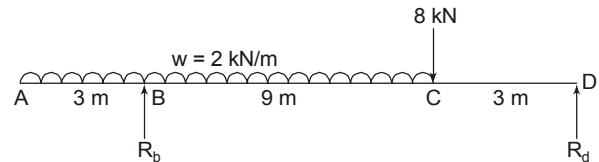

6. (c) Enumerate the situation in which doubly reinforced concrete beams become necessary. What is the role of compression steel? (10)

Essential Table of IS 456 : 2000 Code of Practice IS 456 : 2000

25. 2. 1.1 Design bond stress in limit state method for plain bars in tension shall be as below

Grade of concrete	M 20	M 25	M 30	M 35	M 40 and above
Design bond stress, τ_{bd} , N/mm^2	1.2	1.4	1.5	1.7	1.9

Table 16. Nominal Cover to Meet Durability Requirements (Clause 26.4.2)

Exposure	Nominal Concrete Cover in mm Not Less Than
Mild	20
Moderate	30
Severe	45
Very severe	50
Extreme	75

Notes :

1. For main reinforcement up to 12 mm diameter bar for mild exposure, the nominal cover may be reduced by 5 mm.
2. Unless specified otherwise, actual concrete cover should not deviate from the required nominal cover by $^{+10}_0$ mm.
3. For exposure condition 'severe' and 'very severe', reduction of 5 mm may be made, where concrete grade is M 35 and above

Table 19 : Design Shear Strength of Concrete, τ_o , N/mm²

(Clauses 40.2.1, 40.2.2, 40.4, 40.5.3, 41.3.2, 41.3.3 and 41.4.3)

$100 \frac{A_s}{bd}$	Concrete Grade					
	M 15	M 20	M 25	M 30	M 35	M 40 and above
(1)	(2)	(3)	(4)	(5)	(6)	(7)
≤ 0.15	0.28	0.28	0.29	0.29	0.29	0.30
0.25	0.35	0.36	0.36	0.37	0.37	0.38
0.50	0.46	0.48	0.49	0.50	0.50	0.51
0.75	0.54	0.56	0.57	0.59	0.59	0.60
1.00	0.60	0.62	0.64	0.66	0.67	0.68
1.25	0.64	0.67	0.70	0.71	0.73	0.74
1.50	0.68	0.71	0.74	0.76	0.78	0.79
1.75	0.71	0.75	0.78	0.80	0.82	0.84
2.00	0.71	0.79	0.82	0.84	0.86	0.88
2.25	0.71	0.81	0.85	0.88	0.90	0.92
2.50	0.71	0.82	0.88	0.91	0.93	0.95
2.75	0.71	0.82	0.90	0.94	0.96	0.98
3.00 and above	0.71	0.82	0.92	0.96	0.99	1.01

Note : The term A_s is the area of longitudinal tension reinforcement which continues at least one effective depth beyond the section being considered except at support where the full area of tension reinforcement may be used provided the detailing conforms to 26.2.2 and 26.2.3.

Table 20 : Maximum Shear Stress, $\tau_{c \max}$, N/mm²

(Clauses 40.2.3, 40.2.3.1, 40.5.1 and 41.3.1)

Concrete Grade	M 20	M 25	M 30	M 35	M 40 and above
$\tau_{c \max}$, N/mm ²	2.8	3.1	3.5	3.7	4.0

Table 21 : Permissible Stresses in Concrete

(Clauses B.1.3, B.2.1, B.2.1.2, B. 2. 3 and B-4.2)

All values in N/mm²

Grade of Concrete	Permissible Stress in Compression		Permissible Stress in Bond (Average) for plain Bars in Tension
	Bending	Direct	
(1)	(2)	(3)	(4)
	σ_{cbc}	σ_{cc}	τ_{bd}
M 10	3.0	2.5	—
M 15	5.0	4.0	0.6
M 20	7.0	5.0	0.8
M 25	8.5	6.0	0.9
M 30	10.0	8.0	1.0
M 35	11.5	9.0	1.1
M 40	13.0	10.0	1.2
M 45	14.5	11.0	1.3
M 50	16.0	12.0	1.4

Notes:

1. The values of permissible shear stress in concrete are given in Table 23.
2. The bond stress given in column 4 shall be increased by 25 percent for bars in compression.

4 Question Paper 2016**Table 23 : Permissible Shear Stress in Concrete**

(Clauses B.2.1, B.2.3, B-4.2, B-5.2.1, B.5.2.2, B.5.3, B-5.4, B-5.5.1, B-5.5.3, B-6.3.2, B-6.3.3 and B.6.4.3 and Table 21)

$100 \frac{A_s}{bd}$	Permissible Shear Stress in Concrete, τ_c , N/mm ²					
	Grade of Concrete					
	M 15	M 20	M 25	M 30	M 35	M 40 and above
(1)	(2)	(3)	(4)	(5)	(6)	(7)
≤ 0.15	0.18	0.18	0.19	0.20	0.20	0.20
0.25	0.22	0.22	0.23	0.23	0.23	0.23
0.50	0.29	0.30	0.31	0.31	0.31	0.32
0.75	0.34	0.35	0.36	0.37	0.37	0.38
1.00	0.37	0.39	0.40	0.41	0.42	0.42
1.25	0.40	0.42	0.44	0.45	0.45	0.46
1.50	0.42	0.45	0.46	0.48	0.49	0.49
1.75	0.44	0.47	0.49	0.50	0.52	0.52
2.00	0.44	0.49	0.51	0.53	0.54	0.55
2.25	0.44	0.51	0.53	0.55	0.56	0.57
2.50	0.44	0.51	0.55	0.57	0.58	0.60
2.75	0.44	0.51	0.56	0.58	0.60	0.62
3.00 and above	0.44	0.51	0.57	0.60	0.62	0.63

Note: A_s is the area of longitudinal tension reinforcement which continues at least one effective depth beyond the section being considered excepts at support where the full area of tension reinforcement may be used provided the detailing conforms to 26.2.2 and 26.2.3.

Table 24: Maximum Shear Stress, $\tau_{c \max}$, N/mm²

(Clauses B.5.2.3, B.5.2.3.1, B.5.5.1 and B.6.3.1)

Concrete Grade	M 15	M 20	M 25	M 30	M 35	M 40 and above
$\tau_{c \max}$, N/mm ²	1.6	1.8	1.9	2.2	2.3	2.5

Question Paper 2015

Civil Engineering (Paper II)

1. (a) What are the factors that influence the strength of cement concrete? Briefly discuss the effects of water-cement ratio and workability on the strength of concrete. (15)
- (b) Explain the purpose of conducting soundness test of cement. Describe the apparatus and method of test with the help of neat sketches. (15)
- (c) Give a short description of preservation of wood using various wood preservatives. (10)
- (d) List the four important tests conducted on bricks. Explain the various defects in bricks. (20)
2. (a) Write the characteristics of contour lines. (10)
- (b) The following readings were extracted from a level field book. Some of the entries are missing because of exposure to rain. Insert the missing reading and check your results. (20)

Station	B.S.	I.S.	F.S.	Rise	Fall	RL	Remarks
1.	3.250					?	Bench mark
2.	1.755		?		0.750	?	Change point
3.		1.950			?	?	
4.	?		1.920			?	
5.		2.340		1.500		?	
6.				1.000		?	
7.	1.850		2.185		?	250.00	Change point
8.		1.575		?		?	
9.		?		?		?	
10.	?		1.895		1.650	?	Change point
11.			1.350	0.750		?	Last point

- (c) The soil from a borrow area having an average in-situ unit weight of 15.5 kN/m^3 and water content of 10%, was used for the construction of an embankment (total finished volume 6000 m^3). In half of the embankment due to improper rolling, the dry unit weight achieved was slightly lower. If the dry unit weights in the two parts are 16.5 kN/m^3 and 16.0 kN/m^3 , find the volume of borrow area soil used in each part and the amount of soil used. (15)
- (d) A 6.0 m high retaining wall is to support a soil with unit weight 17.4 kN/m^3 , $\phi = 26^\circ$ and $c' = 14.36 \text{ kN/m}^2$. Determine the Rankine active force per unit length of the wall before the tensile crack occurs. Find the critical depth. (15)
3. (a) Two pipes of diameters 'D' and 'd' and equal length 'L' are arranged in parallel. The loss of head for a flow of 'Q' is 'h'. If the same pipes are arranged in series, the loss of head for the same flow is 'H'. If $d = 0.5 D$, find the percentage of total flow through each pipe when placed in parallel. Also, find the ratio H/h . Neglect minor losses and assume friction factor to be constant. (15)
- (b) Water flows over the spillway of a dam at a depth of 2.73 m over it. The difference of elevation between spillway crest and downstream bed level is 30 m. If the discharge coefficient of spillway is 0.75, determine the water depth after the jump and head loss in the jump. (15)

2 Question Paper 2015

- (c) Calculate the minimum required sight distance to avoid a head-on collision of two cars approaching from the opposite directions at 90 and 60 kmph. Assume reaction time as 2.5 sec and coefficient of friction of 0.7 and brake efficiency 50% in either case. (15)
- (d) Differentiate canal design methods by Lacey and Kennedy. (15)
- 4. (a) A cantilever, 3 m long, is loaded with a uniformly distributed load of 15 kN/m over a length of 2 m from the fixed end. Determine the slope and deflection at the free end of the cantilever. Take $E = 2.1 \times 10^8 \text{ kN/m}^2$ and $I = 0.000095 \text{ m}^4$. (20)
- (b) Draw the flow sheet showing sequence of a typical water treatment with perennial river as source of water. Explain these treatment units sequentially. (20)
- (c) What is meant by solid waste management? Describe briefly the principles of design of a sanitary landfill for solid wastes disposal. (20)
- 5. (a) Explain under-reinforced, balanced and over-reinforced section with respect to WSM as well as LSM. (30)
- (b) Using limit state method (LSM), determine the moment of resistance of the T-Beam as shown in the figure below. Use M 15 concrete and Fe 415 steel. (30)

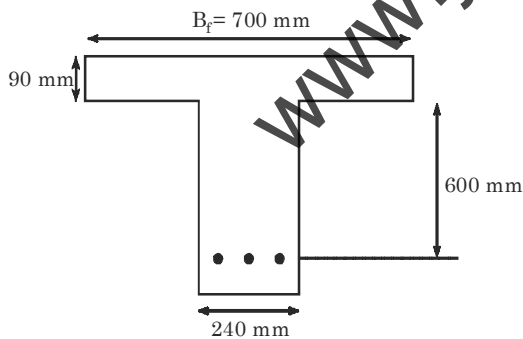

- 6. (a) Explain the following:
 - (i) Elastic curve of mild steel with a suitable diagram showing important points. (10)
 - (ii) Different types of welds with suitable figures and symbols (10)
- (b) A single-bolted double cover butt joint is used to connect two plates which are 8 mm thick. Assuming 16 mm diameter bolts of grade 4.6 and cover plates to be 6 mm thick, calculate

the strength and efficiency of the joint, if 4 bolts are provided in the bolt line at a pitch of 45 mm as shown in the figure below. Take the end distance of the fastener along bearing direction as 30 mm. (40)

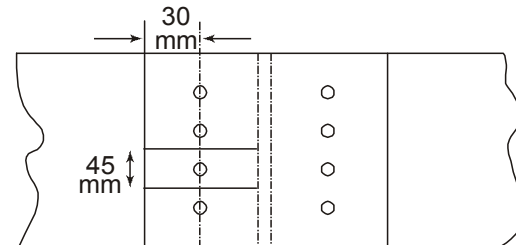

Essential Tables of IS 456 : 2000 Code of Practice IS 456 : 2000

26.2.1.1 Design bond stress in limit state method for plain bars in tension shall be as below:

Grade of concrete	M 20	M 25	M 30	M 35	M 40 and above
Design bond stress, τ_{bd} , N/mm^2	1.2	1.4	1.5	1.7	1.9

Table 16 : Nominal Cover to Meet Durability Requirements

(Clause 26.4.2)

Exposure	Nominal Concrete Cover in mm Not Less Than
Mild	20
Moderate	30
Severe	45
Very severe	50
Extreme	75

Notes :

1. For main reinforcement up to 12 mm diameter bar for mild exposure the nominal cover may be reduced by 5 mm.
2. Unless specified otherwise, actual concrete cover should not deviate from the required nominal cover by $^{+10}_0$ mm.
3. For exposure condition 'severe' and 'very severe', reduction of 5 mm may be made, where concrete grade is M 35 and above.

Table 19: Design Shear Strength of Concrete, τ_c , N/mm².

(Clauses 40.2.1, 40.2.2, 40.3, 40.4, 40.5.3, 41.3.2, 41.3.3 and 41.4.3)

$100 \frac{A_s}{bd}$	Concrete Grade					
	M 15	M 20	M 25	M 30	M 35	M 40 and above
(1)	(2)	(3)	(4)	(5)	(6)	(7)
≤ 0.15	0.28	0.28	0.29	0.29	0.29	0.30
0.25	0.35	0.36	0.36	0.37	0.37	0.38
0.50	0.46	0.48	0.49	0.50	0.50	0.51
0.75	0.54	0.56	0.57	0.59	0.59	0.60
1.00	0.60	0.62	0.64	0.66	0.67	0.68
1.25	0.64	0.67	0.70	0.71	0.73	0.74
1.50	0.68	0.72	0.74	0.76	0.78	0.79
1.75	0.71	0.75	0.78	0.80	0.82	0.84
2.00	0.71	0.79	0.82	0.84	0.86	0.88
2.25	0.71	0.81	0.85	0.88	0.90	0.92
2.50	0.71	0.82	0.88	0.91	0.93	0.95
2.75	0.71	0.82	0.90	0.94	0.96	0.98
3.00 and above	0.71	0.82	0.92	0.96	0.99	1.01

Note: The term A_s is the area of longitudinal tension reinforcement which continues at least one effective depth beyond the section being considered except at support where the full area of tension reinforcement may be used provided the detailing conforms to 26.2.2 and 26.2.3.

Table 20 : Maximum Shear Stress, $\tau_{c \max}$, N/mm²

(Clauses 40.2.3, 40.2.3.1, 40.5.1 and 41.3.1)

Concrete Grade	M 20	M 25	M 30	M 35	M 40 and above
$\tau_{c \max}$, N/mm ²	2.8	3.1	3.5	3.7	4.0

Table 21 : Permissible Stresses in Concrete

(Clauses B-1.3, P.2.1, B-2.1.2 B-2.3 and B-4.2)

All values in N/mm²

Grade of Concrete	Permissible Stress in Compression		Permissible Stress in Bond (Average) for plain Bars in Tension
	Bending	Direct	
(1)	(2)	(3)	(4)
	σ_{cbc}	σ_{cc}	τ_{bd}
M 10	3.0	2.5	—
M 15	5.0	4.0	0.6
M 20	7.0	5.0	0.8
M 25	8.5	6.0	0.9
M 30	10.0	8.0	1.0
M 35	11.5	9.0	1.1
M 40	13.0	10.0	1.2
M 45	14.5	11.0	1.3
M 50	16.0	12.0	1.4

Notes:

1. The values of permissible shear stress in concrete are given in Table 23.
2. The bond stress given in column 4 shall be increased by 25 percent for bars in compression.

4 Question Paper 2015
Table 23 : Permissible Shear Stress in Concrete.

(Clauses B-2.1, B-2.3, B-4.2, B-5.2.1, B-5.2.2, B-5.3, B-5.4, B-5.5.1, B-5.5.3, B-6-3.2, B-6.3.3 and B-6.4.3 and Table 21)

$100 \frac{A_s}{bd}$	Permissible Shear Stress in Concrete, τ_c , N/mm ² Grade of concrete					
	M 15	M 20	M 25	M 30	M 35	M 40 and above
(1)	(2)	(3)	(4)	(5)	(6)	(7)
≤ 0.15	0.18	0.18	0.19	0.20	0.20	0.20
0.25	0.22	0.22	0.23	0.23	0.23	0.23
0.50	0.29	0.30	0.31	0.31	0.31	0.32
0.75	0.34	0.35	0.36	0.37	0.37	0.38
1.00	0.37	0.39	0.40	0.41	0.42	0.42
1.25	0.40	0.42	0.44	0.45	0.45	0.46
1.50	0.42	0.45	0.46	0.48	0.49	0.49
1.75	0.44	0.47	0.49	0.50	0.52	0.52
2.00	0.44	0.49	0.51	0.53	0.54	0.55
2.25	0.44	0.51	0.53	0.55	0.56	0.57
2.50	0.44	0.51	0.55	0.57	0.58	0.60
2.75	0.44	0.51	0.56	0.58	0.60	0.62
3.00 and above	0.44	0.51	0.57	0.60	0.62	0.63

Note: A_s is the area of longitudinal tension reinforcement which continues at least one effective depth beyond the section being considered except at support where the full area of tension reinforcement may be used provided the detailing conforms to 26.2.2 and 26.2.3

Table 24: Maximum Shear Stress, $\tau_{c \max}$, N/mm²

(Clauses B-5.2.3, B-5.2.3.1, B-5.5.1 and B-6.3.1)

Concrete Grade	M 15	M 20	M 25	M 30	M 35	M 40 and above
$\tau_{c \max}$, N/mm ²	1.6	1.8	1.9	2.2	2.3	2.5

Question Paper 2014

Civil Engineering (Paper II)

(Civil and Structural)

1. (a) What are the constituents of good brick-earth? What constituents render brick-earth unsuitable for manufacturing bricks? (10)
- (b) Describe any two tests to be performed in case of burnt clay bricks. (10)
- (c) State the conditions under which you will recommend the following cements. Give also the reasons.
- (i) Rapid hardening cement
- (ii) High alumina cement (10)
- (d) Briefly explain (10)
- (i) Assessed value
- (ii) Sinking fund
- (e) Determine the number of bags of cement required for a standard brick masonry for a wall of thickness 30 cm for a height of 10 m and length 200 m in 1 : 4 mortar. (20)
2. (a) The readings given in the Table below were recorded in a levelling operation from points 1 to 10. Reduce the levels by the height of instrument method and apply appropriate checks. The point 10 is a bench mark having elevation of 66.374 m. Determine the loop closure. (30)

Station	Change (m)	B.S.	I.S.	F.S.	Remarks
1	0	0.597			B.M. = 68.233 m
2	20	2.587		3.132	C.P
3	40		1.565		
4	60		1.911		
5	80		0.376		
6	100	2.244		1.522	C.P
7	120		3.771		
8	140	1.334		1.985	C.P
9	160		0.601		
10	180			2.002	

- (b) A soil sample in its natural state has, when fully saturated, a water content of 32.5%. Determine the void ratio, dry and total unit weight. Calculate the total weight of water required to saturate a soil mass of volume 10 m³. Assume $G_s = 2.69$. (15)
- (c) Describe the method of laying Water Bound Macadam (WBM) road. (15)

2 Question Paper 2014

3. (a) Find the discharge through a rectangular orifice 2.0 m wide and 1.5 m deep fitted to a water tank. The water level in the tank is 3.0 m above the top edge of the orifice. Take $c_d = 0.62$. (30)
- (b) Enumerate the assumptions made in Lacey's theory of canal designs. (15)
- (c) Write short note on types of impurities in water in the light of domestic supply. (15)
4. (a) Draw the shear force and bending moment diagram and label the values of the largest positive and negative shearing forces and bending moments for the beams with overhang as shown in Figure 1. (30)

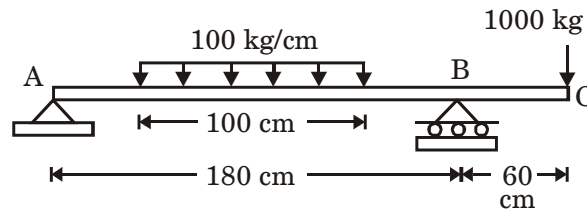
**Fig. 1**

- (b) Describe the various defects in concrete along with precautions that should be exercised to prevent them. (30)
5. (a) Describe briefly creep and shrinkage. (20)
- (b) A rectangular, singly reinforced beam 300 mm wide and 500 mm effective depth is used as a simply supported beam over an effective span of 6 m. The reinforcement consists of 4 bars of 20 mm diameter. If the beam carries a load of 12 kN/m (inclusive of self weight), determine the stress developed in concrete and steel. Take $m = 19$. (40)
6. (a) Classify welded joints according to type of joints. (20)
- (b) A single rivet lap joint is used to connect 12 mm thick plates by providing 20 mm diameter rivets at 50 mm pitch. Determine the strength of the joint and joint efficiency. Take working stress in shear in rivets = 80 N/mm², working stress in bearing in rivets = 250 N/mm² and working stress in axial tension in plates = 156 N/mm². (40)

JK Chrome

JK Chrome | Employment Portal



Rated No.1 Job Application of India

Sarkari Naukri
Private Jobs
Employment News
Study Material
Notifications

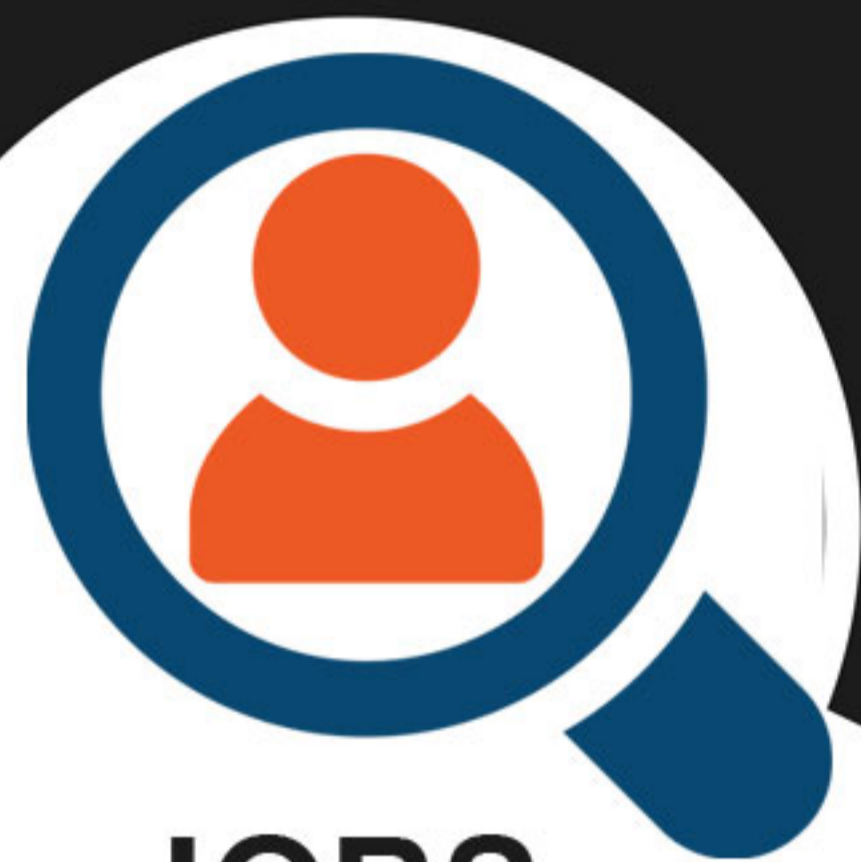

JOBS



NOTIFICATIONS



G.K



STUDY MATERIAL

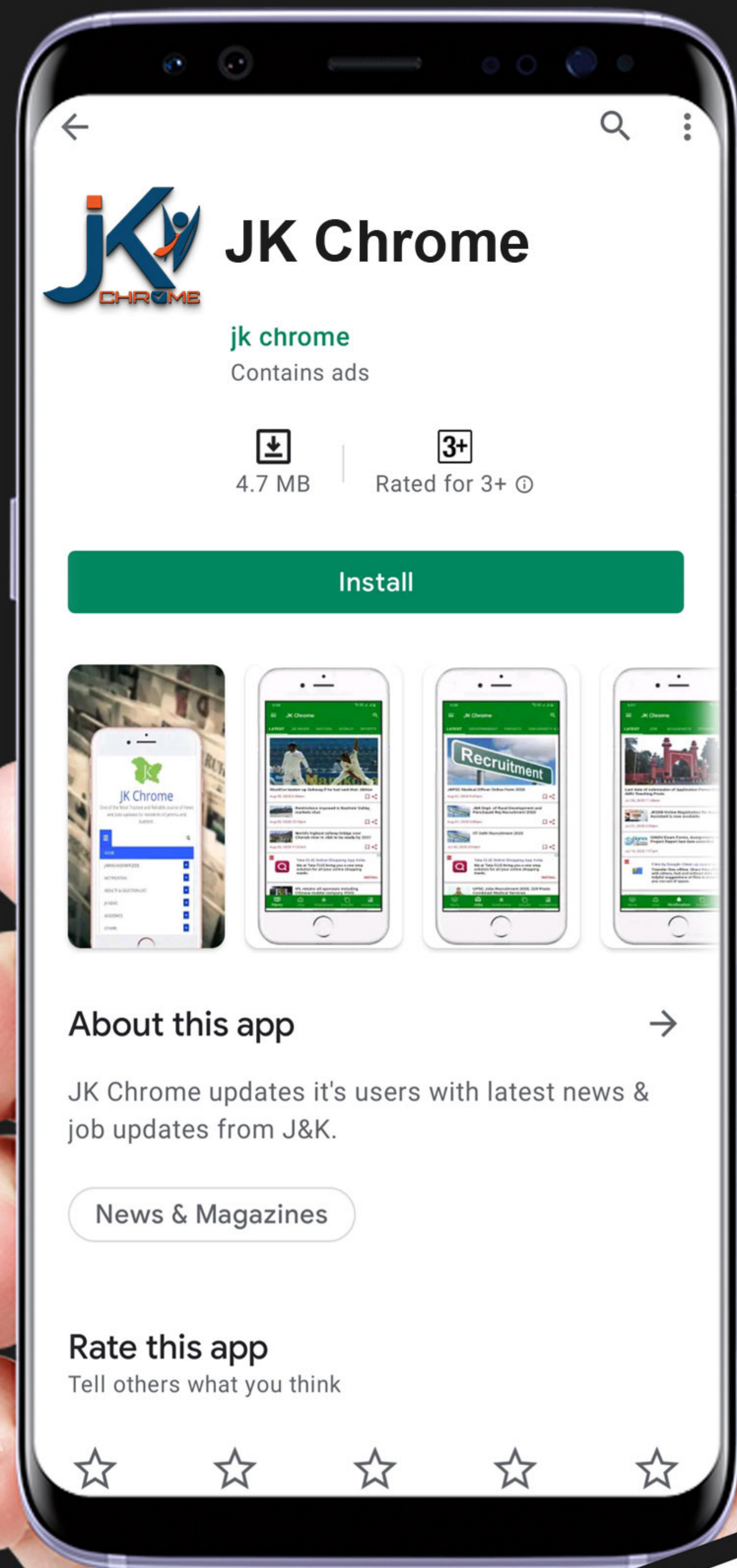

www.jkchrome.com | Email : contact@jkchrome.com

Question Paper 2013

Civil Engineering (Paper II)

(Civil and Structural)

1. (a) Write a short note on Night Irrigation. (15)
 (b) Give a brief account of the drawbacks in Kennedy's theory. (15)
 (c) For a Highway project, a straight tunnel is to be run between two points P and Q whose co-ordinates are given below:

Point	Co-ordinates	
	N	E
P	0	0
Q	4020	800
R	2110	1900

It is desired to sink a shaft at S, the mid-point of PQ. S is to be fixed from R, the third known point. Calculate

- (i) The co-ordinates of S
 (ii) The length of RS
 (iii) The bearing of RS (15)
- (d) Find out the time required for 50% consolidation in a soil having thickness of 800 cm and pervious strata at top and bottom. What will be the value of coefficient of consolidation if coefficient of permeability = 0.0000001 cm/sec? (15)
- Void ratio = 1.8, $m_v = 0.0003 \text{ cm}^2/\text{gm}$
 Time factor (T_v) = 0.3
 $\gamma_w = 1 \text{ gm/cc}$
2. (a) Calculate the ultimate bearing capacity per unit area of:
- (i) A strip footing 1 m wide
 (ii) A square footing 3m × 3 m
 (iii) A circular footing of diameter 3 m
- Given:
 Unit weight of the soil 1.8 t/m³, cohesion = 2t/m² and $\phi = 20$ degree. $N_c = 17.5$, $N_q = 7.5$ and $N_r = 5$. (15)

- (b) Calculate the discharge through a pipe of dia. 200 mm when the difference of pressure head between two ends of a pipe 500 m apart is 4 m of water. Take the value of $f = 0.009$ in the formula

$$h_f = \frac{4 \cdot f \cdot L \cdot V^2}{d \cdot 2g} \quad (15)$$

- (c) Compare and contrast Flexible and Rigid pavements. (15)
- (d) Discuss the impact of Urbanisation and Industrialisation in water resource (in terms of both quantity and quality). (15)
3. (a) The annual sinking fund of a machine costing ₹ 50,000 is ₹ 150 and its salvage value is estimated to be ₹ 5,000. Assuming interest rate as 4%, determine the life of the machine. (20)
- (b) Describe the factors affecting the rate analysis. (10)
- (c) Write a short note on the classification of bricks. (15)
- (d) Discuss the constituent parts of paint and their functions. (15)
4. (a) List the physical tests that are generally used on cement. Describe any three of them. (15)
- (b) Discuss the relation between water-cement ratio and strength. (15)
- (c) Design a cantilever beam which projects beyond the fixed end by 3m. The superimposed load on it is 10 kN/m. Use M 20 grade ($\sigma_{cbc} = 7 \text{ N/mm}^2$) of concrete and Fe 415 steel ($\sigma_{st} = 230 \text{ N/mm}^2$). Assume moderate exposure conditions. (30)

2 Question Paper 2013

5. A simply supported 18 m effective span RCC rectangular beam of 500 mm × 1500 mm (overall depth) section is reinforced throughout with 21 nos. 25 mm diameter bars in three layers of 7 bars each at clear cover of 37.5 mm on tensile face. The reinforcement on the compression face is 4 – 25 mm + 1 – 20 mm diameter bars in one layer at an effective cover of 50 mm. The clear cover between the different layers on tension face is 25 mm. M 25 grade concrete and Fe 415 grade steel bars are used in the beam throughout. The beam is laterally restrained throughout the span.

- (a) What shall be the superimposed uniformly distributed load w , that the beam can carry at working conditions? (15)
- (b) Design the shear reinforcement at support if design shear strength of concrete τ_c is given as follows for different values of $p = 100 A_s / bd$. (15)

p	1.25	1.5	1.75
τ_c (MPa)	0.70	0.74	0.78

- (c) Calculate the moment of resistance of the compound steel section shown in the figure. The compound section consists of two steel sections ISMB 200 @ 25.4 kg/m ($I_{xx} = 2235.4 \text{ cm}^4$, $A_{xx} = 32.33 \text{ cm}^2$) with a single cover plate, 40 cm wide and 16 mm thick connected to the top flange. Assume bending stress = 150 MPa. (15)

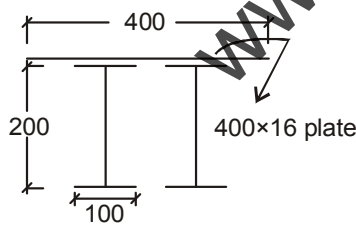

Dimensions in mm

(d) A mild steel T section has the following cross-sectional dimensions:

Total depth = 200 mm

Width of flange = 120 mm

Thickness of flange = 20 mm

Thickness of web = 20 mm

If the yield stress, $\sigma_y = 250 \text{ MPa}$, determine the plastic moment capacity of the section. Also calculate the shape factor for the section. (15)

- 6. (a) Analyze the beam shown in figure and determine the end moments. Plot the B.M.D. on the tension side. (30)

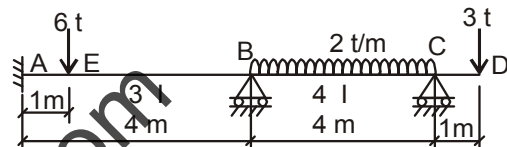

- (b) Analyze the portal frame shown in the figure. Also sketch the deflected shape of the frame. The end A is fixed and the end D is hinged. Also, the value of EI is constant throughout. (30)

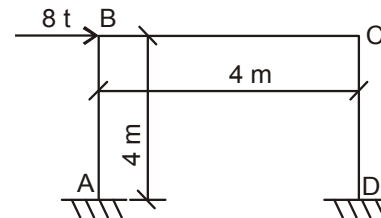

Essential Tables of IS : 456 : 2000 Code of Practice

26.2.1.1 Design bond stress in limit state method for plain bars in tension shall be as below:

Grade of concrete	M 20	M 25	M 30	M 35	M 40 and above
Design bond stress, τ_{db} , N/mm ²	1.2	1.4	1.5	1.7	1.9

Table 16 : Nominal Cover to Meet Durability Requirements (Clause 26.4.2)

Exposure	Nominal Concrete Cover in mm Not Less Than
Mild	20
Moderate	30
Severe	45
Very severe	50
Extreme	75

Notes :

1. For main reinforcement up to 12 mm diameter bar for mild exposure the nominal cover may be reduced by 5 mm.
2. Unless specified otherwise, actual concrete cover should not deviate from the required nominal cover by ${}^{+10}_0$ mm.
3. For exposure condition 'severe' and 'very severe', reduction of 5 mm may be made, where concrete grade is M 35 and above.

Table 19 : Design Shear Strength of Concrete, τ_c , N/mm²

(Clauses 40.2.1, 40.2.2, 40.3, 40.4, 40.5.3, 41.3.2, 41.3.3 and 41.4.3)

$100 \frac{A_s}{bd}$	Concrete Grade					
	M 15	M 20	M 25	M 30	M 35	M 40 and above
(1)	(2)	(3)	(4)	(5)	(6)	(7)
≤ 0.15	0.28	0.28	0.29	0.29	0.29	0.30
0.25	0.35	0.36	0.36	0.37	0.37	0.38
0.50	0.46	0.48	0.49	0.50	0.50	0.51
0.75	0.54	0.56	0.57	0.59	0.59	0.60
1.00	0.60	0.62	0.64	0.66	0.67	0.68
1.25	0.64	0.67	0.70	0.71	0.75	0.76
1.50	0.68	0.72	0.74	0.76	0.78	0.79
1.75	0.71	0.75	0.78	0.80	0.82	0.84
2.00	0.71	0.79	0.82	0.84	0.86	0.88
2.25	0.71	0.811	0.85	0.88	0.90	0.92
2.50	0.71	0.82	0.88	0.91	0.93	0.95
2.75	0.71	0.82	0.90	0.94	0.96	0.98
3.00 and above	0.71	0.82	0.92	0.96	0.99	1.01

Note: The term A_s is the area of longitudinal tension reinforcement which continues at least one effective depth beyond the section being considered except at support where the full area of tension reinforcement may be used provided the detailing conforms to 26.2.2 and 26.2.3.

Table 20 : Maximum Shear Stress, $\tau_{c\max}$, N/mm²

(Clauses 40.2.3, 40.2.3.1, 40.5.1 and 41.3.1)

Concrete Grade	M 20	M 25	M 30	M 35	M 40 and above
$\tau_{c\max}$, N/mm ²	2.8	3.1	3.5	3.7	4.0

4 Question Paper 2013**Table 21 : Permissible Stresses in Concrete**(Clauses B-1.3, B-2.1, B-2.1.2, B-2.3 and B-4.2) All values in N/mm²

Grade of Concrete	Permissible Stress in Compression		Permissible Stress in Bond (Average) for plain Bars in Tension
	Bending	Direct	
(1)	(2)	(3)	(4)
	σ_{abc}	σ_{cc}	τ_{bd}
M 10	3.0	2.5	–
M 15	5.0	4.0	0.6
M 20	7.0	5.0	0.8
M 25	8.5	6.0	0.9
M 30	10.0	8.0	1.0
M 30	11.5	9.0	1.1
M 35	13.5	10.0	1.2
M 45	14.5	11.0	1.3
M 50	16.0	12.0	1.4

Notes:

- The values of permissible shear stress in concrete are given in Table 23.
- The bond stress given in col. 4 shall be increased by 25 percent for bars in compression.

Table 23 : Permissible Shear Stress in Concrete

(Clauses B-2.1, B-2.3, B-4.2, B-5.2.1, B-5.2.2, B-5.3, B-5.4, B-5.5.1, B-5.5.3, B-6.3.2, B-6.3.3 and B-6.4.3 and Table 21)

$100 \frac{A_s}{bd}$	Permissible Shear Stress in Concrete, τ_c , N/mm ² Grade of concrete					
	M 15	M 20	M 25	M 30	M 35	M 40 and above
(1)	(2)	(3)	(4)	(5)	(6)	(7)
≤ 0.15	0.18	0.18	0.19	0.20	0.20	0.20
0.25	0.22	0.22	0.23	0.23	0.23	0.23
0.50	0.29	0.30	0.31	0.31	0.31	0.32
0.75	0.34	0.35	0.36	0.37	0.37	0.38
1.00	0.37	0.39	0.40	0.41	0.42	0.42
1.25	0.40	0.42	0.44	0.45	0.45	0.46
1.50	0.42	0.45	0.46	0.48	0.49	0.49
1.75	0.44	0.47	0.49	0.50	0.52	0.55
2.00	0.44	0.49	0.51	0.53	0.54	0.55
2.25	0.44	0.51	0.53	0.55	0.56	0.57
2.50	0.44	0.51	0.55	0.57	0.58	0.60
2.75	0.44	0.51	0.56	0.58	0.60	0.62
3.00 and above	0.44	0.51	0.57	0.60	0.62	0.63

Note: A_s is the area of longitudinal tension reinforcement which continues at least one effective depth beyond the section being considered except at support where the full area of tension reinforcement may be used provided the detailing conforms to 26.2.2 and 26.2.3.

Table 24 : Maximum Shear Stress, $\tau_{c\max}$, N/mm²

(Clauses B-5.2.3, B-5.2.3.1, B-5.5.1 and B-6.3.1)

Concrete Grade	M 15	M 20	M 25	M 30	M 35	M 40 and above
$\tau_{c\max}$, N/mm ²	1.6	1.8	1.9	2.2	2.3	2.5

Question Paper 2012

Civil Engineering (Paper II)

(Civil and Structural)

1. (a) What are the chief chemical ingredients and their percentage used in the manufacturing of Portland cement? Also briefly explain the Bogue components and their properties in the cement. (20)
- (b) Explain **any four** of the following thermal insulation : (5 × 4 = 20)
 - (i) Slab or block insulation
 - (ii) Blanket insulation
 - (iii) Bat insulating materials
 - (iv) Insulating boards
- (c) Explain Whole Circle Bearing system. The following bearings were observed with a compass. Calculate the interior angles. (20)

LINE	FORE BEARINGS
AB	60° 30'
BC	122° 00'
CD	46° 00'
DE	205° 30'
EA	300° 00'

2. (a) What is superelevation? Derive the relation between superelevation and speed of vehicle on horizontal curve. Design the rate of superelevation for a horizontal curve of a radius 500 m and speed 100 km/hr. (5 + 15)
- (b) Describe the terms – True and Magnetic bearings; local attraction; back bearings and magnetic declination. (20)
- (c) Explain the term Base period and Crop period. After how many days will you order irrigation in order to ensure healthy growth of crops if : (20)
 - (i) Field capacity of soil = 29%
 - (ii) Permanent wilting point = 11%
 - (iii) Density of soil = 1300 kg/m³
 - (iv) Effective depth of root zone = 700 mm
 - (v) Daily consumptive use of water of the given crop = 12 mm

Consider moisture content must not be less than 25% of the water holding capacity between the field capacity and permanent wilting point.

3. (a) What do you mean by "Viscosity"? Velocity distribution of a fluid of dynamic viscosity is 8.63 poise is $U = 2/3y - y^2$ in which U is the velocity in m/sec at a distance y meter above the plate. determine the shear stress at y = 0 and y = 0.15. Take dynamic viscosity of fluid is 8.63 poise. (20)
- (b) Define air pollution. Enlist natural and man made air pollution. What are the effects of air pollution on human, plants and materials? (5 + 5 + 10 = 20)
- (c) Define the term BOD, COD and TDS. The 5 days 30°C BOD of sewage sample is 110 mg/l. Calculate its 5 days 20°C BOD. Assume the deoxygenation constant at 20°C k_{20} as 0.1? (3 × 3 + 11 = 20)
4. (a) Two plates 6 mm thick are joined by 14 mm diameter rivets in a triple staggered riveted lap joint as shown in fig 1. In what way will the joint fail if allowable tensile stress for plate = 150 MPa; allowable shear stresses for rivets = 90 MPa and allowable bearing stress for rivets = 270 MPa. Also find the efficiency of the joint. (20)

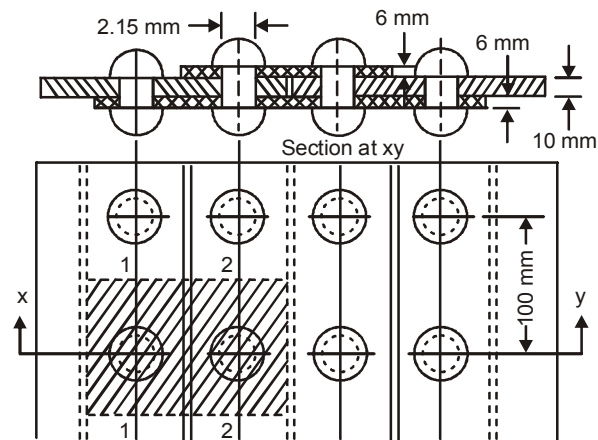

Fig. 1

2 Question Paper 2012

(b) A sand deposit is 10 m thick and overlies a bed of soft clay. The ground water table is 3m below the surface. If the sand above the ground water table has a degree of saturation of 45%, plot the diagram showing the

variation of the total stress, pore water pressure and the effective stress. The void of the sand is 0.70. Take $G = 2.65$. (20)

(c) Draw the shear force and bending moment diagrams for the beam shown in fig. 2 (20)

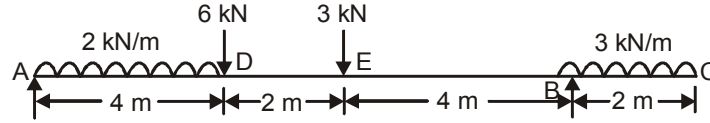

Fig. 2

5. (a) The cross - section of a joist as a T-section, $120 \text{ mm} \times 200 \text{ mm} \times 12 \text{ mm}$, with 120 mm side horizontal. Sketch the shear stress distribution and hence find the maximum shear stress if it has to resist a shear force of 200 kN. (25)

(b) For the I section shown in fig. : 3 determine the position of centroid and moment of inertia about the base flange (I_{KL}).

(10 + 10 = 20)

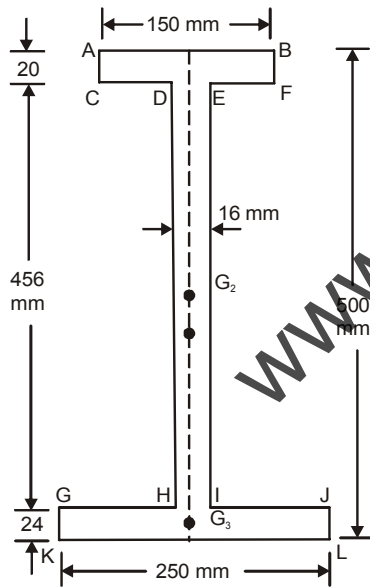

Fig. 3

(c) (i) What is bond? Explain flexural and anchorage bond. (6)

(ii) What is development length? Write its significance in RCC design.

(4 + 5 = 9)

6. (a) A singly reinforced beam having a width of 250 mm is reinforced with 3 bars of 16 mm diameter at an effective depth of 400 mm. If M20 grade concrete and Fe415 HYSD bars are used, compute for the section.

(15 + 15)

(i) Working moment of resistance

(ii) Ultimate moment of resistance

(b) Design a square column section subjected to concentrated load of 1000 kN at service. Consider concrete grade of M25 and steel grade Fe 415. (10)

(c) Design a built - up column composed of two channel sections placed back to back, carrying an axial load of 1345 kN. Effective length of column is 4.95 m. Take $f_y = 250 \text{ kN/mm}^2$.

(20)

Question Paper 2011

Civil Engineering (Paper II)

SECTION – I

(Civil)

1. (a) Write a short note on Consumptive use of water. (15)
- (b) Advantages and disadvantages of concrete sleeper. (15)
2. (a) To determine the mean elevation of a station O interpolated in a triangulation system, the following observations were made :

Station	Height of Inst.	Station observed	Distance in m	Height of signal	Vertical angle	Remarks
O	1.53	D	3684	5.58	+1°1'20"	R sin 1° = 30.88 m
	1.53	E	4698	4.11	-0°52'50"	m = 0.07
	1.53	F	5028.6	4.9	-0°34'10"	log sin 1° = 6.685575

Find the mean elevation of station O, given that the elevations of D, E and F are 293.58, 157.725 and 179.355 respectively. (15)

- (b) In a consolidation test on a soil, the void ratio of the sample decreases from 1.24 to 1.12 when they pressure is increased from 20 to 40 tonnes/sq.m. Calculate the co-efficient of consolidation in m²/year, given that the co-efficient of permeability of the soil during this pressure increment is 8.5×10^{-3} cm/sec. (15)
3. (a) In a plate bearing test on pure clayey soil failure occurred at a load of 12.2 tonnes. The size of the plate was 45 cm × 45 cm and the test was done at the depth of 1.0 m below ground level. Find out the ultimate bearing capacity for a 1.5 m wide continuous wall footing with its base at a depth of 2 m below the ground level. The unit weight of clay may be taken as 1.9 gm/cc and $N_c = 5.7$ and $N_q = 1$ and $N_r = 0$. (20)
- (b) Write a short note on the significant properties of soil. (10)
4. (a) A rectangular channel 2.0 m wide has a discharge of 250 lit/sec which is measured by a right angled V-notch weir. Find the position of the apex of the notch from the bed of the channel if the maximum depth of the water is not to exceed 1.3 m. Take $C_d = 0.62$. (18)
- (b) List down the modes of water penetration into road structure with a neat sketch. (12)
5. (a) Measure to control water pollution. (10)
- (b) A room 600 cm long and 500 cm wide has a flat roof. There is one T-beam in the centre (cross section below the slab 30 cm × 50 cm) and the slab is 15 cm thick. Estimate the quantity of iron bars required for reinforcement (for the T-beam only) from the data given below :
Main bars – 8 nos. of 25 mm dia. in 2 rows of 4 each (all 4 in the bottom being straight and others being bent)
Stirrups – 10 mm dia. and 15 cm centre to centre throughout
Anchor bears – 2 nos. of 16 mm dia. (20)
6. (a) What is analysis of rates ? And explain its purpose. (15)
- (b) Explain the manufacturing of cement by wet process. (15)

Question Paper 2010

Civil Engineering (Paper II)

SECTION – I (Civil)

1. (a) Describe the classification of rocks. (10)
 (b) What are the ingredients of a varnish? Describe the various types of varnishes. (10)
 (c) Discuss the manufacture of cement. (10)
2. (a) A steel tape is 30 m long at a temperature of 15° C and a pull of 50 N when laid on the flat. The tape weight 18 N. It is stretched between end supports only allowing it to sag. Find the correct length of the tape at a field temperature of 25° C at a pull of 115 N. If in the above condition a base line is measured and the recorded length of the line is 600 m, find the correct length of the base line.
 Take $\alpha = 12 \times 10^{-6}$ per °C and $E = 2 \times 10^8$ N/mm². Sectional area of the tape = 7.50 mm² (14)
 (b) Write brief notes on the following: (16)
 (i) Prismatic compass
 (ii) Plane table and its accessories.
3. (a) The following properties of the soil were determined by performing tests on clay sample:
 Natural moisture content = 25 %
 Liquid limit = 32%
 Plastic limit = 24%
 Diameter of 60% size = 0.006 mm
 Diameter of 10% size = 0.006 mm
 Calculate the liquidity coefficient, uniformity coefficient and relative consistency. (15)
 (b) A sample of soil 10 cm diameter, 15 cm length was tested in a variable head permeameter. The initial head of water in the burette was found to be 45 cm and it was observed to drop to 30 cm in 195 seconds. The diameter of the burette was 1.9 cm. Calculate the coefficients of permeability in metre/day. (15)
4. (a) Explain standard penetration test for measuring the penetration resistance of the soil. (12)
 (b) An earthen embankment is compacted to a dry density of 1.82 gm/cc at a moisture content of 12%. The bulk density and moisture content are 1.72 gm/cc and 6% at the site from where the soil is borrowed and transported at the site of construction. How much excavation should be carried out in the pit of borrowed area for each cu-m of the embankment. (18)
5. (a) An oil of viscosity 1.0 poise and relative density 1.05 is flowing through a circular pipe of diameter 5 cm and of length 200 m. The rate of flow is 3.52 l/sec. Find the shear stress at the pipe wall. (12)
 (b) Lubricating oil of specific gravity 0.85 and dynamic viscosity 0.01 kgf-s/m² is pumped through a 3 cm diameter pipe. If pressure drop per metre length of the pipe is 0.15 kgf/cm², determine the mass flow rate in kg/min, the shear stress at the pipe wall, the Reynolds number of flow and the power required per 40 m length of pipe to maintain the flow. (18)
6. (a) Discuss in detail the physical and chemical characteristics of sewage. (18)
 (b) Design a rapid sand filter system for a water supply of 9 m.l.d. to a township. All the principle components shall be designed. Enumerate your assumptions during the design steps. (12)

2 Question Paper 2010

SECTION – II

(Structural)

7. (a) Draw S.F. and B.M. diagram for the beam shown in Fig. 1. (10)

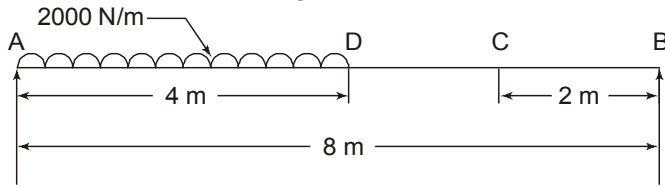

Fig. 1

- (b) Find the moment of inertia of the triangular section shown in Fig. 2. (10)

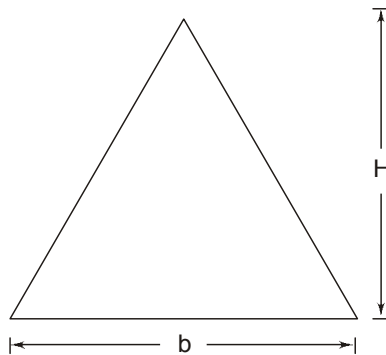

Fig. 2

- (c) A straight circular bar of steel 1 cm in diameter and 120 cm long is mounted in testing machine and located axially in compression till it buckles. Assuming the Euler formula for pinned ends to apply, estimate the maximum central deflection before the material reaches its yield stress of 350 N/mm².

$E = 0.21 \times 10^5 \text{ N/mm}^2$. (10)

8. (a) For the beam shown in Fig. 3, find deflection at the free end and the middle of span. (15)

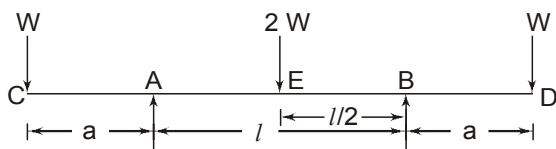

Fig. 3

- (b) Describe the properties of water which are necessary to be used to get good concrete. What do you understand by the term 'water cement ratio'? (15)

9. (a) Describe various methods of mixing concrete. (15)

- (b) Discuss in detail the 'underwater concreting'. (15)

10. (a) Determine the maximum superimposed distributed load which the beam section 220 mm × 440 mm (effective cover = 40 mm)

reinforced with total area of tension steel 1256.64 mm², can carry, if the effective span is 5 m. Use M 20 concrete and Fe 415 steel. Take $m = 13.33$. (15)

- (b) Design a floor slab simply supported over a clear span of 3.5 m. The roof is to be finished with 18.5 mm thick layer of lime concrete terracing. The superimposed load on the slab is 3000 N/m². Use M 20 grade of concrete and high yield strength deformed bars. Take weight of lime concrete as 19.2 kN/m³. (15)

11. Design a square footing of uniform thickness for an axially loaded column of 400 mm × 400 mm in size. The safe bearing capacity of soil is 200 kN/m², load on column = 1000 kN. Use M 20 grade of concrete and HYSD bars. (30)

12. (a) A 16 mm thick plate is joined by double cover butt joint using a 10 mm thick cover plate. The steel of main and cover plate has permissible tensile strength of 150 MPa. Determine the strength and efficiency of the joint per pitch of 9 cm if.

(i) 20 mm diameter power driven shop rivet is used.

(ii) 20 mm diameter close tolerance and turned bolts are used. (20)

Take $\sigma_p = 300 \text{ MPa}$, $T_{vf} = 100 \text{ Mpa}$.

- (b) Find the safe load that can be transmitted by fillet-welded joint shown in Fig. 4. The size of the weld is 6 mm. ($P_q = 108 \text{ MPa}$). (10)

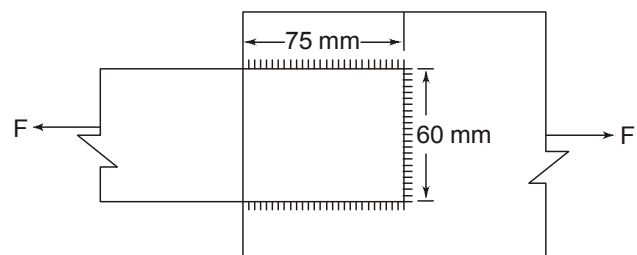

Fig. 4

Question Paper 2009

Civil Engineering (Paper II)

SECTION – I

(Civil)

1. (a) Describe briefly the characteristics of good stones. (10)
- (b) What do you mean by Seasoning of Timber? Describe the methods of seasoning timber. (10)
- (c) Describe the various ingredients of a paint. (10)
2. (a) Discuss in detail the methods of plane table surveying. (15)
- (b) The true bearing of a tower T as observed from a station A was 357° ; the magnetic bearing of the same was 9° . The back bearings of the lines AB, AC and AD were found to be 286° , 337° and 30° respectively when measured with a prismatic compass. Find the true bearings of the lines AB, AC and AD respectively. (15)
3. (a) A sample of soil has a porosity of 35 percent and specific gravity of solids is 2.67. Calculate void ratio, dry density and unit weight if
 - (i) the soil is 50% saturated,
 - (ii) the soil is 100% saturated. (15)
- (b) A sample of soil is 5 cm high and 8 cm in diameter. It was tested in a constant head permeameter. Water percolates through the soil under a constant head of 45 cm for 8 m. The water was collected and weighed. Its weight was recorded as 500 gm. On oven drying the sample of soil, the weight was recorded as 450 gm. If G is 2.65 calculate
 - (i) coefficient of permeability,
 - (ii) seepage velocity of water when the water was under operation. (15)
4. (a) An embankment was compacted at a moisture content of 15%. Its density was determined with the help of a core cutter and the following data was collected:

empty weight of the cutter = 1200 gm
weight of cutter when it is full of soil = 3200 gm
volume of the cutter = 1000 cc

Calculate bulk density and saturation percentage of the embankment. If the embankment becomes fully saturated due to rains, then, determine its moisture content and saturated density. Take $G = 2.70$. (20)
- (b) Explain the factors which affect the bearing capacity of soils. (10)
5. (a) The space between two parallel plates 4 mm apart is filled with an oil of specific gravity 0.85. The upper plate of area 800 cm^2 is dragged with constant velocity of 0.75 m/s by applying a force of 0.2 kgf to it. Assume straight line velocity distribution and calculate velocity gradient, dynamic viscosity of oil in poise and kinematic viscosity of oil in stokes. (15)
- (b) A bend in pipeline conveying water gradually reduces from 60 cm to 30 cm diameter and deflects the flow through an angle of 60° . At the larger end the gauge pressure is 1.75 kg/cm^2 . Determine the magnitude and direction of the force exerted on the bend
 - (i) when there is no flow,
 - (ii) when the flow is 876 lit/sec. (15)
6. (a) Describe in detail the methods employed to purify water, before supplying to the consumers. (18)
- (b) Design a septic tank, for a small colony of 300 persons with average daily sewage flow of 85 litres per head. Detention period is 30 hours. Clearing interval is 6 months. (12)

2 Question Paper 2009

**SECTION – II
(Structural)**

7. (a) A bar 40 mm in diameter is subjected to a tensile force of 40,000 kg. The extension of bar measured over a gauge length of 200 mm was 0.318 mm. The decrease in diameter was found to be 0.02 mm. Calculate values of Young’s modulus of elasticity and modulus of rigidity of the material. (10)
- (b) Draw S.F and B.M. diagrams for beam loaded with varying load as shown in Fig.1 (10)

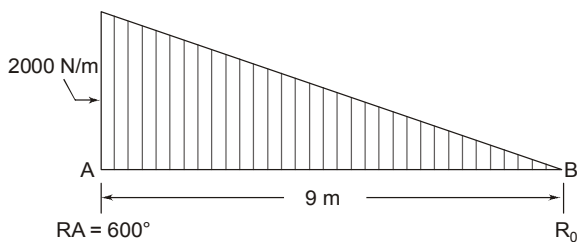

Fig. 1

- (c) An R.S.J. 55 cm deep and 19 cm wide having flange and web thicknesses of 1.5 cm and 0.99 cm respectively is used as a beam. Calculate the moments of resistance at a section where maximum stress is 100 N/mm².
8. (a) A cantilever of length ‘l’ and depth ‘d’ tapers in plan in such a way that the breadth ‘b’ at the fixed end, decreases to zero at the free end. Determine the deflection at the free end due to load ‘W’ acting at the free end (Fig.2.)

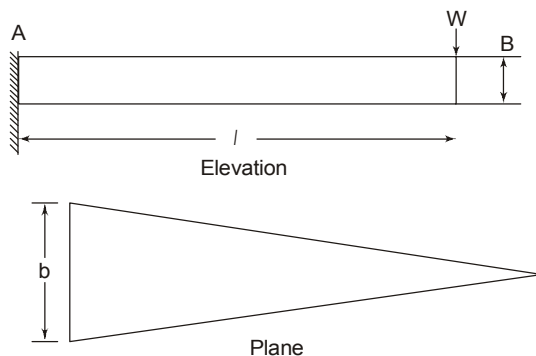

Fig. 2

- (b) Write short notes on:

- (i) Workability of concrete
(ii) Slump test (18)

9. (a) What do you understand by the term ‘curing’? Why is it essential to cure concrete? What are the various methods commonly adopted in curing? (15)
- (b) Discuss in detail “placing of concrete in cold and hot weather”. (15)
10. (a) A reinforced concrete beam 400 mm × 650 mm (effective) in section is reinforced with 3 bars of 28 mm φ. If the effective span is 5 m, find the concentrated load the beam can support at the centre. Assume M 20 concrete and Fe 250 steel (n = 13.33). (15)
- (b) Design a column to carry a load of 590 kN. Height of the column is 3.5 m effective, one side of the column is restricted to 250 mm. Use $\sigma_{cc} = 5 \text{ N/mm}^2$, $\sigma_{sc} = 190 \text{ N/mm}^2$ and 10 mm φ lateral ties. (15)
11. Design a cantilever slab to carry a superimposed load of 4188 N/m². The overhang of the slab is 1.2 m. Adopt M 20 concrete and Fe 415 steel. (30)
12. (a) What are the advantages and disadvantages of welded joints? (12)
- (b) Determine the maximum load in the rivets of the eccentric connection shown in Fig. 3. (18)

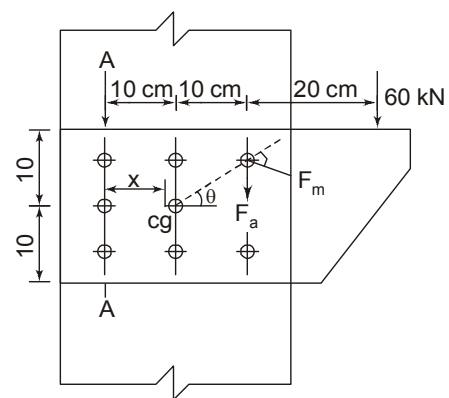

Fig. 3

Essential Tables of IS 456:2000 Code of Practice

26.2.1.1 Design bond stress in limit state method for plain bars in tension shall be as below:

<i>Grade of concrete</i>	M 20	M 25	M 30	M 35	M 40 and above
<i>Design bond stress, τ_{bd}, N/mm²</i>	1.2	1.4	1.5	1.7	1.9

Table 16: Nominal Cover to Meet Durability Requirements (Clause 26.4.2)

Exposure	Nominal Concrete Cover in mm Not Less Than
Mild	20
Moderate	30
Severe	45
Very severe	50
Extreme	75

Notes:

1. For main reinforcement up to 12 mm diameter bar for mild exposure the nominal cover may be reduced by 5 mm.
2. Unless specified otherwise, actual concrete cover should not deviate from the required nominal cover by +10 mm.
3. For exposure condition 'severe' and 'very severe' reduction of 5 mm may be made, where concrete grade is M 35 and above.

Question Paper 2008

Civil Engineering (Paper II)

SECTION – I (Civil)

1. (a) Discuss the operations involved in the manufacture of bricks. (10)
- (b) Describe the following tests to be performed in case of burnt clay bricks: (10)
 - (i) Compressive strength test
 - (ii) Water absorption test
- (c) Write a brief note on the characteristics of good timber. (10)
2. (a) A chain line CDE crosses a river, D and E being on the near and distant banks respectively. A perpendicular DF 54.865 m long is set out at D on the left of the chain line. The respective bearings of E and C taken at F are $67^{\circ} 30'$ and $157^{\circ} 30'$. Find the chainage of E, given that CD is 27.630 m and the chainage of D is 382.52 m. (15)
- (b) Define and explain contour, contour interval, necessity of contour plotting. Discuss factors affecting the choice of contour interval. (15)
3. (a) A sample of dry soil having specific gravity of 2.74 and having a mass of 133.7 gm is uniformly dispersed in water to form 1000 cc of suspension.
 - (i) Determine the density of suspension immediately after it is prepared.
 - (ii) A 10 cc of the suspensions was removed from the depth of 21 cm beneath the top surface after the suspension was allowed to stand for 2 min 30 sec. The dry mass of the soil in the sample drawn was found to be 0.406 gm. Determine one point on the grain-size distribution curve corresponding to this observation.
Temperature of suspension = 20°C
Viscosity of water at 20°C = 0.0102 poise (15)
- (b) 60 cm diameter well is being pumped at a rate of 1360 litres/minute. Measurements in a nearby test well were made at the same time as follows. At a distance of 6 m from the well being pumped, the drawdown was 6 m, and at 15 m the drawdown was 1.5 m. The bottom of the well is 90 m below the ground water table.
 - (i) Find out the coefficient of permeability.
 - (ii) If all the observed points were on the Dupuit curve, what was the drawdown in the well during pumping?
 - (iii) What is the specific capacity of the well?
 - (iv) What is the rate at which water can be drawn from this well? (15)
4. (a) A direct shear box test performed on a remoulded sand sample yielded the following observation at the time of failure:

Normal load = 0.36 kN
Shear load = 0.18 kN
The sample area was 36 cm^2 .

 Determine:
 - (i) the angle of internal friction,
 - (ii) the magnitude and direction of the principal stresses in the zone of failure, and
 - (iii) the magnitude of maximum deviator stress if a sample of the same sand with the same void ratio were tested in a triaxial test with an all-round pressure of 60 kN/m^2 . Assume $c = 0$. (18)
- (b) A 2.2 m square footing is located at a depth of 4.4 m in a stiff clay of saturated unit weight 21 kN/m^3 . The undrained strength of clay at a depth of 4.4 m is given by parameter $w = 120\text{ kN/m}^2$ and $\phi_u = 0$. For a factor of safety 3, with respect to shear failure, compute
 - (i) the net value of bearing capacity, and
 - (ii) the value of maximum load that could be carried by the footing. (12)
5. (a) The space between two square flat parallel plates is filled with oil. Each side of the plate is 60 cm. The thickness of the oil film is 12.5 mm. The upper plate, which moves at 2.5 m per sec requires a force of 98.1 N to maintain the speed.

JK Chrome

JK Chrome | Employment Portal



Rated No.1 Job Application of India

Sarkari Naukri
Private Jobs
Employment News
Study Material
Notifications



JOBS



NOTIFICATIONS



G.K



STUDY MATERIAL

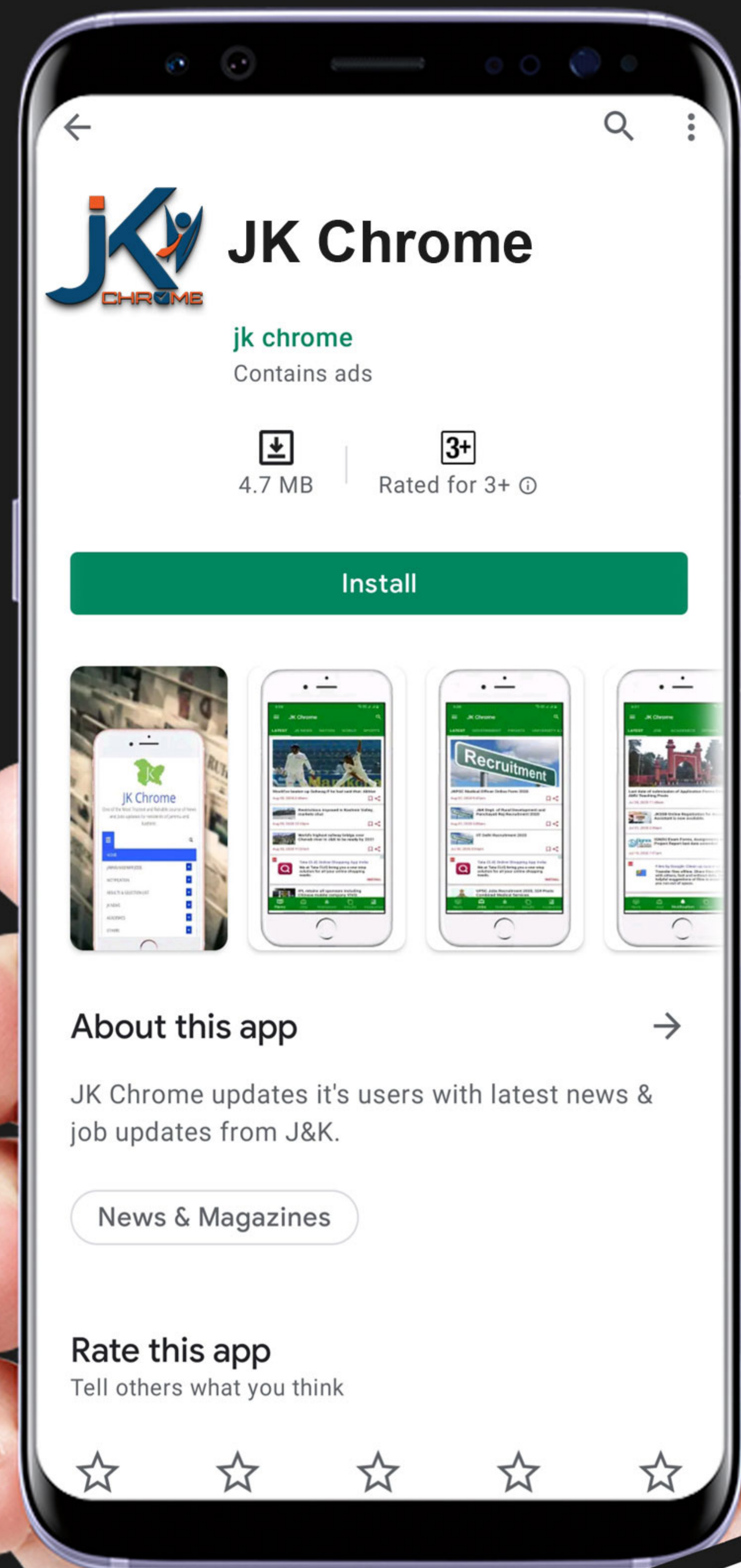

JK Chrome

jk chrome
Contains ads



www.jkchrome.com | Email : contact@jkchrome.com

2 Question Paper 2008

- Determine:
- (i) the dynamic viscosity of the oil, in poise, and
 - (ii) the kinematic viscosity of the oil, in stokes, if the specific gravity of the oil is 0.95. (15)
- (b) A pelton wheel is to be designed for the following specifications:
 Shaft power = 11,772 kW; Head = 330 m;
 Speed = 750 r.p.m.; Overall efficiency = 86%;
 Diameter is not to exceed one-sixth of the wheel diameter:
 Determine:

- (i) the wheel diameter,
 - (ii) the number of jets required, and
 - (iii) diameter of the jet.
- Take coefficient of velocity = 0.985 and speed ratio = 0.45. (15)

6. (a) Write short notes on the following: (12)
- (i) Sewer
 - (ii) Sewage
 - (iii) Sewerage system
 - (iv) Drain and trench drain
- (b) Design a 15×10^6 l.p.d water treatment plant with rapid gravity sand filter. Assume suitable design parameters (18)

SECTION – II
(Structural)

7. (a) When a bar of certain material 40 cm square is subjected to an axial pull of 1,60,000 N the extension on a gauge length of 200 mm is 0.1 mm and the decrease in each side of the square is 0.005 mm. Calculate Young's modulus, Poisson's ratio shear modulus and bulk modulus for this material. (10)
- (b) Draw S.F. and B. M. diagrams for the beam having overhangs on both sides and loaded as shown in Fig. 1. (20)

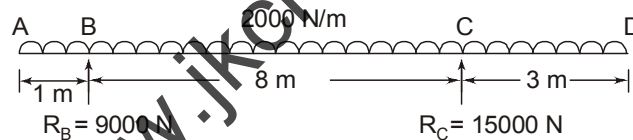

Fig.1

8. (a) Find the deflections at points D and C of the beam loaded as shown in Fig. 2. (15)

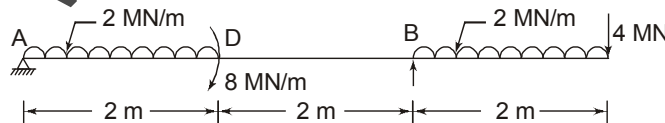

Fig. 2

- (b) A solid steel column and a hollow steel column, both have the same length and same cross-section area, and are fixed at the ends. If the internal diameter of hollow column is $2/3$ of its external diameter, find the ratio of buckling strengths of solid steel column to that of hollow steel column. (15)
9. (a) Explain the important properties of cement concrete both in plastic and hardened stage. (15)
- (b) Describe the sequence of concreting operations. (15)
10. (a) A particular sand sample of 250 grams, when sieved successively through the following sieves, left retentions on the sieves as follows:

IS sieve	10 mm	480	240	120	60	30	15
Retention grams	NIL	10	15	50	50	75	50

What is its fineness modulus? What sand is it – fine, medium or coarse? (10)

- (b) Design a simply supported R.C.C. slab for an office floor having clear dimensions of 4 m by 10 m with 230 mm walls all-around. Adopt M-20 grade concrete and Fe-415 grade HYSD bars. (20)
11. Design a cantilever retaining wall to retain an earth embankment 4 m high above ground level. The density of earth is 18 kN/m^3 and its angle of repose is 30° . The embankment is horizontal at top. The safe bearing capacity of the soil may be taken as 200 kN/m^2 and the coefficient of friction

between soil and concrete is 0.5. Adopt M-20 grade concrete and Fe-415 HYSD bars. (30)

12. (a) Find the suitable pitch for single riveted lap joint for plates 1 cm thick, if $\sigma_t = 150 \text{ N/mm}^2$, $\sigma_s = 100 \text{ N/mm}^2$ and $\sigma_b = 300 \text{ N/mm}^2$. (12)
- (b) Calculate the maximum load that the bracket shown in Fig. 3 can carry if the size of the weld on flange is 8 mm and that on the web is 5 mm. The allowable shear stress is 102.5 N/mm^2 . (18)

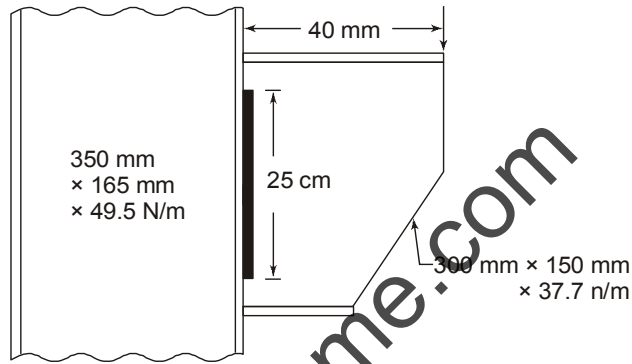

Fig. 3

Essential Tables of IS: 456: 2000 Code of Practice IS 456 : 2000

26.2.1.1 Design bond stress in limit state method for plain bars in tension shall be as below:

Grade of concrete	M 20	M 25	M 30	M 35	M 40 and above
Design bond stress, σ_{bd} N/mm^2	1.2	1.4	1.5	1.7	1.9

Table 16: Nominal Cover to Meet Durability Requirements (Clause 26.4.2)

Exposure	Nominal Concrete Cover in mm Not Less Than
Mild	20
Moderate	30
Severe	45
Very severe	50
Extreme	75

Notes:

- For main reinforcement up to 12 mm diameter bar for mild exposure the nominal cover may be reduced by 5 mm.
- Unless specified otherwise, actual concrete cover should not deviate from the required nominal cover by + 10₀ mm.
- For exposure condition 'severe' and 'very severe', reduction of 5 mm may be made, where concrete grade is M 35 and above.

4 Question Paper 2008**Table 19 : Design Shear Strength of Concrete, τ_c , N/mm².**

(Clauses 40.2.1, 40. 2, 2, 40.3, 40.4, 40.5.3, 41.3.2, 41.3.3 and 41.4.3)

$100 \frac{A_s}{bd}$	Concrete Grade					
	M 15	M 20	M 25	M 30	M 35	M 40 and above
(1)	(2)	(3)	(4)	(5)	(6)	(7)
≤ 0.15	0.28	0.28	0.29	0.29	0.29	0.30
0.25	0.35	0.36	0.36	0.37	0.37	0.38
0.50	0.46	0.48	0.49	0.50	0.50	0.51
0.75	0.54	0.56	0.57	0.59	0.59	0.60
1.00	0.60	0.62	0.64	0.66	0.67	0.68
1.25	0.64	0.67	0.70	0.71	0.75	0.76
1.50	0.68	0.72	0.74	0.76	0.78	0.79
1.75	0.71	0.75	0.78	0.80	0.82	0.84
2.00	0.71	0.79	0.82	0.84	0.86	0.88
2.25	0.71	0.811	0.85	0.88	0.90	0.92
2.50	0.71	0.82	0.88	0.91	0.93	0.95
2.75	0.71	0.82	0.90	0.94	0.96	0.98
3.00 and above	0.71	0.82	0.92	0.96	0.99	1.01

Note : The term A_s is the area of longitudinal tension reinforcement which continues at least one effective depth beyond the section being considered except at support where the full area of tension reinforcement may be used provided the detailing conforms to 26.2.2 and 26.2. 3.

Table 20 : Maximum Shear Stress, $\tau_{c \max}$, N/mm².

(Clauses 40.2.3, 40.2.3.1, 40.5.1, and 41. 3. 1.)

Concrete Grade	M 20	M 25	M 30	M 35	M 40 and above
$\tau_{c \max}$, N/mm ²	2.8	3.1	3.5	3.7	4.0

Table 21: Permissible Stresses in Concrete(Clauses B-1.3, B-2.1, B-2.1.2, B-2.3 and B-4.2) All values in N/mm²

Grade of Concrete	Permissible Stress in Compression		Permissible Stress in Bond (Average) for plain Bars in Tension
	Bending	Direct	
(1)	(2)	(3)	(4)
	σ_{cbc}	σ_{cc}	τ_{bd}
M 10	3.0	2.5	–
M 15	5.0	4.0	0.6
M 20	7.0	5.0	0.8
M 25	8.5	6.0	0.9
M 30	10.0	8.0	1.0
M 35	11.5	9.0	1.1
M 40	13.0	10.0	1.2
M 45	14.5	11.0	1.3
M 50	16.0	12.0	1.4

Notes:

1. The values of permissible shear stress in concrete are given in Table 23.
2. The bond stress given in col. 4 shall be increased by 25 percent for bars in compression.

Table 23: Permissible Shear Stress in Concrete

(Clauses B-2.1, B-2.3, B-4.2, B-5.2.1, B-5.2.2, B-5.3, B-5.4, B-5.5.1, B-5.5.3, B-6.3.2, B-6.3.3 and B-6.4.3 and Table 21)

$100 \frac{A_s}{bd}$	Permissible Shear Stress in Concrete, τ_c , N/mm ² Grade of concrete					
	M 15	M 20	M 25	M 30	M 35	M 40 and above
(1)	(2)	(3)	(4)	(5)	(6)	(7)
≤ 0.15	0.18	0.18	0.19	0.20	0.20	0.20
0.25	0.22	0.22	0.23	0.23	0.23	0.23
0.50	0.29	0.30	0.31	0.31	0.31	0.32
0.75	0.34	0.35	0.36	0.37	0.37	0.38
1.00	0.37	0.39	0.40	0.41	0.42	0.42
1.25	0.40	0.42	0.44	0.45	0.45	0.46
1.50	0.42	0.45	0.46	0.48	0.49	0.49
1.75	0.44	0.47	0.49	0.50	0.52	0.55
2.00	0.44	0.49	0.51	0.53	0.54	0.55
2.25	0.44	0.51	0.53	0.55	0.56	0.57
2.50	0.44	0.51	0.55	0.57	0.58	0.60
2.75	0.44	0.51	0.56	0.58	0.60	0.62
3.00 and above	0.44	0.51	0.57	0.60	0.62	0.63

Note: A_s is the area of longitudinal tension reinforcement which continues at least one effective depth beyond the section being considered except at support where the full area of tension reinforcement may be used provided the detailing conforms to 26.2.2 and 26.2.3.

Table 24: Maximum Shear Stress, $\tau_{c \max}$, N/mm²

(Clauses B.5.2.3, B.5.2.3.1, B.5.5.1 and B.6.3.1.)

Concrete Grade	M 15	M 20	M 25	M 30	M 35	M 40 and above
$\tau_{c \max}$, N/mm ²	1.6	1.8	1.9	2.2	2.3	2.5

Question Paper 2007

Civil Engineering (Paper II)

SECTION – I (Civil)

1. Differentiate between the following materials giving specific uses in the building industry:

(6 + 8 + 8 + 8)

- Igneous, sedimentary and metamorphic rocks
 - Bitumen, coal tar and asphalt
 - Common burnt clay bricks, firebricks and flyash bricks
 - Paints and varnish
2. (a) A river is flowing from West to East. For determining the width of the river, two points A and B are selected on the southern bank such that the distance $AB = 75$ m. Point A is Westward. The bearings of a tree C on the Northern bank are observed to be 38° and 338° , respectively from A and B. Calculate the width of the river. (20)
- (b) What are contour gradients? Explain their importance in the location of a hill road. (10)
3. (a) A 10 m thick bed of sand is underlain by a layer of clay 6 m thick. The water table that was originally at ground level is lowered by drainage to a depth 4 m, whereupon the degree of saturation above lowered water table reduces to 20%. Determine the increase in the effective pressure at mid of clay layer due to water table lowering. Given saturated densities of sand and clay as 2.1 g/cm^3 and 1.8 g/cm^3 , and the dry density of sand = 1.7 g/cm^3 .
- Note :** $[\text{g/cm}^3 = 10^3 \text{ kg/m}^3 \times 9.8 \text{ m/s}^2 = 9.81 \text{ kN/m}^2]$. (20)
- (b) An earth embankment is compacted at water content of 17% to a bulk density of 1.9 g/cc . If the sp. gr. of soil grains is 2.65 calculate the void ratio of the compacted embankment. (10)
4. (a) The space between two parallel horizontal plates is kept 5 mm apart. This is filled with

crude oil of dynamic viscosity 2.5 kg/m.s . If the lower plate is stationary and the upper plate is pulled with velocity of 1.75 m/s , determine the shear stress on the lower plate. (15)

- (b) An open tank 5 m long, 2 m deep and 3 m wide contains oil of relative density 0.9 to a depth of 0.9 m. If the tank is accelerated along its length on a horizontal track at a constant value of 5 m/s^2 , determine the new position of oil surface. (15)
5. (a) Calculate the diameter and discharge of a circular sewer laid at a slope of 1 in 400, running half-full and with velocity 1.9 m/s ($n = 0.012$). (15)
- (b) The 5-day BOD of a waste is 280 mg/l . The ultimate BOD is reported to be 410 mg/l . At what rate the waste is being oxidised? (15)
6. (a) What are the various methods of doing theodolite traversing? Describe the deflection angle method in detail. (10)
- (b) What soil investigations are required for constructing (i) an embankment and (ii) a building? Give details. (10)
- (c) Write a note on flow measurement methods employed for pipe flow and open channels (with specific reference to drains). (10)

SECTION – II (Structural)

7. (a) Draw SF and BM diagrams for the beam with applied moment as shown in Fig. 1. (15)

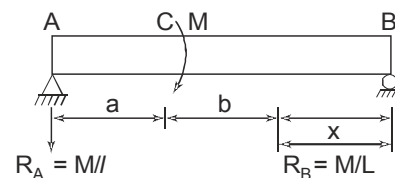

Fig. 1

- (b) A bar 40 mm in diameter is subjected to a tensile force of 40000 kg. The extension of bar measured over a gauge length of 200 mm

2 Question Paper 2007 (PAPER II)

was 0.318 mm. The decrease in diameter was found to be 0.02 mm. Calculate the values of Young's modulus of elasticity and modulus of rigidity of the material. (15)

8. (a) Find the slope and deflection at the free end of a cantilever shown in Fig. 2. Moment of inertia of AC is twice the moment of inertia of BC. (15)

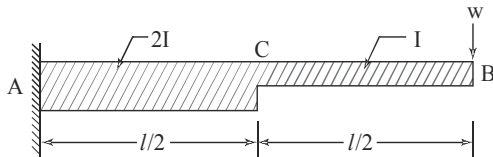

Fig. 2

- (b) The I-beam shown in Fig. 3 is simply supported at its ends over a 4 m span and carries central load of 50000 N which acts through the centroid, the line of action being as shown in Fig. 3. Calculate the maximum stress. (15)

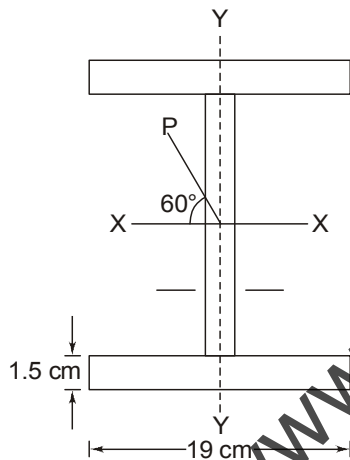

Fig. 3

9. (a) Explain briefly the importance of different concretes in construction. (10)
 (b) List the properties of cement concrete in plastic and hardened stage (5)
 (c) Explain briefly the terms batching, mixing transporting, compacting and curing. (15)
10. (a) A reinforced concrete beam 30 cm × 60 cm in section is reinforced with 4 bars 16 φ at top and 5 bars 22 φ at bottom with an effective cover of 4 cm. Assume safe compressive strength of concrete = 50 kg/cm²; $\sigma_{sc} = 1400$ kg/cm²; $m = 19$. Find moment of resistance (WSM). (15)
 (b) Design a reinforced concrete beam with balanced section for flexure by working stress method for the data given below: (WSM) (15)

Effective span (simply supported) = 8 m
 Live load = 12 kN/m
 Breadth of the beam = 300 mm
 Concrete grade = M 20
 Reinforcement steel grade = Fe 415

11. Design a circular tank of 13.75 m diameter and 3.0 m height of wall. Free board = 0.3 m. The tank rests on a firm ground. The walls are fixed at base and free at top. (LSM). (30)
12. (a) The bracket shown in Fig. 4 consists of pair of mild steel plates riveted to the flanges of 305 mm × 152 mm I-column. If the resultant force on the critical rivet is limited to 45 kN, determine the load P, the bracket can support. (15)

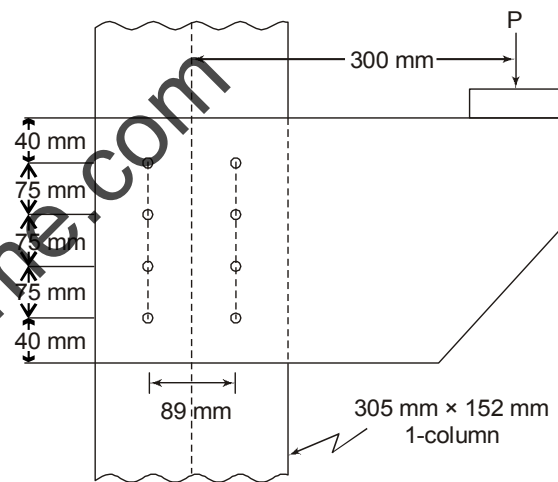

Fig. 4

- (b) Calculate the size of the weld required for the welded bracket loaded as shown in Fig. 5. (15)

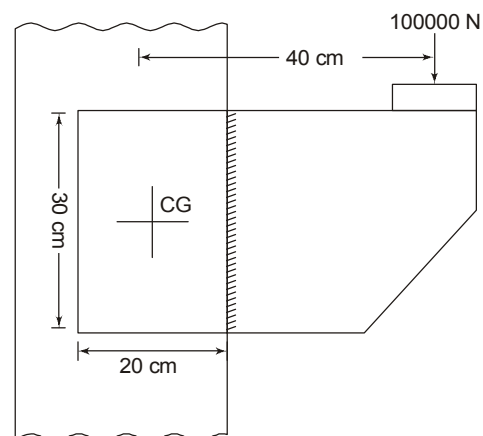

Fig. 5

JK Chrome

JK Chrome | Employment Portal



Rated No.1 Job Application of India

Sarkari Naukri
Private Jobs
Employment News
Study Material
Notifications



JOBS



NOTIFICATIONS



G.K



STUDY MATERIAL

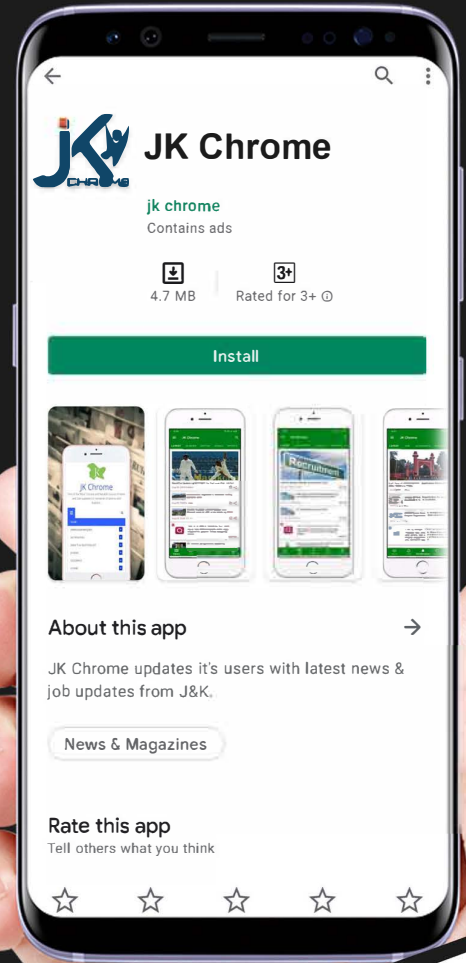

JK Chrome

jk chrome
Contains ads



www.jkchrome.com | Email : contact@jkchrome.com